

NWT Apprenticeship Support Materials



Science

* *Module 1 – Foundations*



Reading Comprehension

* *Module 2 – Science Development*

* *Module 3 – Special Topics*



Math

PARTNERS



Copyright

Copyright 2003 The Apprenticeship Support Materials Consortium. All rights reserved.

First Printing: February 2003

Second Printing: March 2004

All partners listed below may copy the materials for distribution and use in the Northwest Territories only. Use of the material by any other organization or in any location other than the Northwest Territories requires the permission of The Apprenticeship Support Materials Consortium.

Acknowledgements:

The Apprenticeship Support Materials Project has been a true partnership. The challenge has been to develop a set of study materials, which covers every competency in the "Entrance Level Competencies for Apprenticeship Programs" developed by Alberta Advanced Education, Apprenticeship and Industry Training. These study materials although written for Northerners using northern examples, issues and problems, are appropriate for any individual entering the trades. The goal is to equip Northerners for the Trades Entrance Exam as well as to support them through the apprenticeship process.

The following partner organizations have all contributed to the development of these materials:

De Beers Canada Mining Inc. – Snap Lake Diamond Project
Government of the Northwest Territories – Education, Culture and Employment
Government of Canada – Indian and Northern Affairs Canada
Government of Canada – Human Resources Development Canada
Government of Canada – Canadian Rural Partnership
Aurora College
Skills Canada NWT/NU
The Genesis Group Ltd.

Author







Thomas O'Connor M.A., Education Consultant with the Genesis Group Ltd., is the author of the NWT Apprenticeship Support Materials.

The Partnership Steering Committee wishes to acknowledge his dedication to the goals of northern adult education.



Table of Contents

Module 3 – Special Topics

Introduction	5
Science Competencies For Trades Entrance	5
 Unit 1 – Matter and Motion	9
Topic 1 – Forces And Fields	9
Topic 2 – Velocity And Acceleration	13
Topic 3 – Newton’s Laws Of Motion	24
Topic 4 – Circular Motion And Gravity	28
Topic 5 – Conservation of Momentum	31
 Unit 2 – Energy and Work	35
Topic 1 – Work And Energy	35
Topic 2 – Efficiency And Power	45
 Unit 3 – Electricity	49
Topic 1 – Current, Voltage and Resistance	49
Topic 2 – Circuits	53
Topic 3 – Electrical Power	60
Topic 4 – Transformers	63
 Unit 4 – Light	66
Topic 1 – Electromagnetic Waves	65
Topic 2 – Properties of Light	69
 Unit 5 – Practice Exam Questions	75
Resources	109
 Appendix: Alberta List of Competencies	111

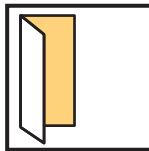

Introduction

This curriculum is designed for independent study. It can also be used to support study groups, one on one tutoring, and classroom lessons. Science Special Topics is part three of three modules that cover all five levels of the Alberta list of science competencies required for the trades entrance examination.¹

A curriculum for Math and for reading comprehension is also available to provide a complete resource for trades entrance exam preparation in the Northwest Territories.

Math Foundations Are Required

All trades entrance candidates are expected to understand the competencies covered in the four parts of the math core curriculum. The science curriculum makes use of the math skills covered there. You may decide to study math and science together.

The trades entrance examination is based on a competency based approach. This means that **what you know – not how you learned it**, will be assessed. It also means that **only what you need to know for entrance into a trade will be assessed**.

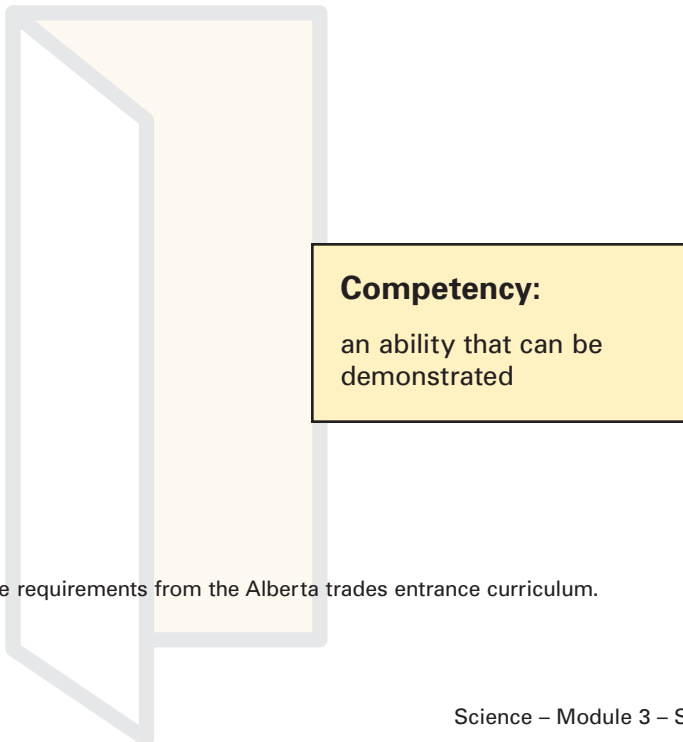

.....
¹ See Appendix A: trades entrance requirements from the Alberta trades entrance curriculum.

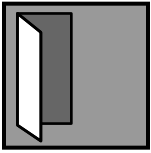

Introduction

When you choose a trade to prepare for, you need to know how much of the science curriculum will be on your trades entrance exam. Each version of the exam is designed for a specific group of trades. See your apprenticeship advisor to learn which exam level is required for your choice of a trade, then use the chart below to decide which category you are in:

NWT Apprenticeship Support Materials Exam Level Requirements

Exam Levels 1 & 2	Exam Levels 3 & 4	Exam Level 5
Reading Comprehension	Reading Comprehension	Reading Comprehension
Math I, II, III, IV	Math I, II, III, IV	Math I, II, III, IV, V
Science I	Science I, II	Science I, II, III
Curriculum Sources: <ol style="list-style-type: none"> 1. Alberta list of Trades Entrance Competencies 2. Education, Culture and Employment Grid of Trades Entrance Competencies 		

This diagram shows how each module of the curriculum relates to an exam level that builds on earlier modules.

Module 1: Foundations

Science Foundations (required for all Exam Levels)

Module 2: Science Development

Science Development (requires Module 1 and adds material required for Exam Levels 3 and 4)

Module 3: Special Topics

Science Special Topics (requires Modules 1 and 2, and adds material required for Exam Level 5.)

Your choice of a trade will determine how many of the three science guides cover the material that will be on your trades entrance exam.

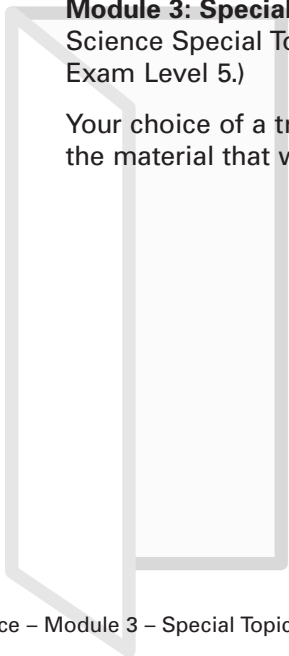

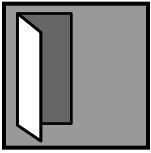

Introduction

Examples are the focus

In this curriculum guide, examples with explanations are the primary tool used for review. Background for each competency is also given with a brief overview of what you need to know. Before any examples are given, the main ideas in each topic are explained and “need to know” information is summarized in rules and definitions.

Organization of Content²

You may want to skip the background given on a topic and go right to the examples to see how well you do. You can always go back to the theory if you find you need it. Study the textboxes titled: “what you need to know about...”, and these will give you the main points for exam preparation.

There are three study guides for trades entrance science. Each module assumes that you understand the material covered in the previous module.³

Example:

An oil burner mechanic candidate needs to prepare for Exam Levels 3 and 4. He will study Science 1: **Foundations**, and Science 2: **Science Development**. An electronics technician candidate needs to study Module 3: **Science Special Topics**, in addition to Science 1 and 2.

The three sections of the curriculum build on each other. For example, the material in Module 2: **Science Development** on heat transfer assumes that you already know the foundation material on temperature and heat in Module 1. In Module 3, special topics relating heat to waves and energy are covered. These topics assume that you already understand the material on heat and energy covered in Modules 1 and 2.

² For a more detailed introduction see “Science competencies for trades entrance” in the introduction for Section One: Science Foundations.

³ This curriculum follows the Alberta list of competencies in science. In some cases, levels are combined in the curriculum but may be separated in the number of levels described as necessary for a trade. For example, this curriculum groups all level 3 competencies with level four, because a roofer who only needs level three competencies according to one grid, may be tested on level four competencies as well because they are not separated in the master list of competencies prepared by the Alberta Department of Apprenticeship and Industry Training. By following the Alberta list of competencies, this curriculum supports apprenticeship goals by erring on the side of potentially including more, rather than less, material in each category.

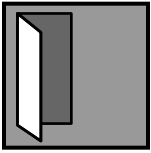

Introduction

Pre-Test Yourself

Each module of the science curriculum ends with practice exam questions that you can use to assess yourself before and after you study the material in a module. The recommended strategy is to "work backwards". Take some of the practice questions for the highest level you are responsible for. For example, if you are preparing for exam levels 3 and 4, try some questions at the end of Module Two: **Science Development**. If you get the score you want, you should get a similar score on the exam for trades that require exam levels 3 and 4.

The results will guide you to the place in the curriculum where you should begin your review. The Practice Exam Questions are the same kinds of questions that you will find on your trades entrance exam. They are in multiple choice format.

An answer key identifies the part of the curriculum that explains how to answer each question. Many candidates for the exam find that they need to start with Module One to review science foundations. Many people find that review goes quickly, but that new learning takes more time.

Organization of Topics in Each Module

The emphasis in trades is on using science to solve practical problems quickly and correctly. Each topic in this curriculum guide includes

1. Background and Theory
2. Examples with Explanations
3. Practice Exam Questions with Answers

This curriculum guide outlines competencies, but does not provide detailed lessons, as for example in a science textbook. If you need more instruction on a particular competency, you may find these and other resources helpful. The steps given to explain how to solve problems are written as if you were talking to yourself, or thinking out loud. Read every sentence carefully, there are no wasted words if you are learning a competency for the first time. The right approach is to start slow: think carefully through each explanation. If you get this part right, you will be able to solve all of the problems in the competency area.

If you turn to a competency required for your exam and don't understand the explanation, you can read the earlier modules that lead up to it. The competencies are covered in a logical order from simple to more complex concepts and problems. Each module builds on what came before. Many people find it helpful to read through the overview for each competency area before going to the specific competencies they need. Key concepts are introduced when they are first needed. For example, density is introduced before the topic of buoyancy in Module Two. The basic concepts of heat and temperature are introduced in Module One before they are developed in problems on heat transfer and change in the volume of materials in Module Two.

When several terms are used for the same thing, the expression "aka," meaning "also known as" is sometimes used to reinforce useful equivalent meanings.

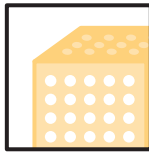

Unit 1

Matter and Motion

Topic 1 – Forces And Fields

Field theory is one of the most important ideas in modern science. A field is a region where we can observe the behavior of objects that are affected by forces. Examples include filings attracted to a magnet, (magnetic force) pieces of paper attracted to an electrically charged comb, (electric force) and objects falling to earth (gravitational force).

Vectors are used to describe the direction and magnitude of forces.⁴ Three fields that involve force are of interest in this Module: gravitational fields, electric fields, and magnetic fields.

The idea of a field is used to understand "action at a distance". Unlike contact forces, for example pulling an object with a rope, electrical, gravitational, and magnetic forces can act on objects even when they are not touching each other. The idea of a field was developed by Michael Faraday (1791-1867) in his study of electrical force.

In each case a test object allows us to measure the strength and direction of the force acting in a field.

An Electric Field

You can find an electric field in the space between two metal plates that are facing each other with a small distance between them when one plate is connected to the positive terminal of a battery, and one is connected to the negative terminal. Any charged particles placed in the space will be moved towards the surface with the opposite charge to that carried by the particle.

.....
⁴ See math module 5- Special Topics, Unit two: Vectors



Topic 1 – Forces And Fields

In the case of electrical fields, a charge sets up a field that exists in all points in all directions radiating out from the charge. Think of a sphere surrounding the charge such that the force exerted by the charge lessens as the radius increases. This is also true for mass because a mass will set up a gravitational field that radiates in all directions. This is also true for magnetic objects that set up a field (flux) that radiates in all directions. In each case the strength of the field can be calculated using test objects and seeing how they behave at different locations in a field.

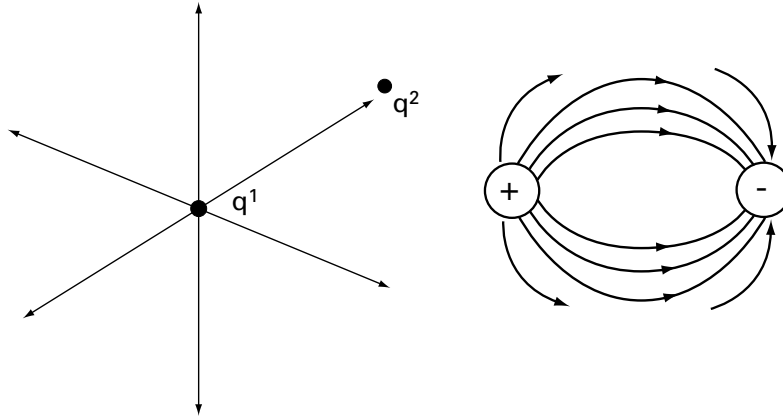

In this diagram you can see how lines of force are used to represent an electric field. The charge q_1 is positive. A positive test charge, q_2 would be repelled and driven away from q_1 , and a negative charge would be attracted. When two opposite charges interact you can see how the field lines describe the region between the charges. Depending on where a test object with a smaller charge than q_1 and q_2 is placed in the field, and what its sign is, it will be attracted to one side or the other.

An electric field is defined in a similar way to a gravitational field, namely as the force exerted per unit of charge at any point in the field.⁵ Just as gravitational force is exerted on units of mass in a gravitational field, so is a force exerted on charged particles in an electric field. When a charged comb causes hair to lift up from your head, an electric field is involved that is stronger than the force of gravity that normally holds your hair down.

Recall that gravity is a force that is exerted per unit of mass at any point in a gravitational field. **Electric potential** is the potential energy per unit of charge in the electric field.⁶ Similar observations can be made about magnetic force.

Each field can be defined as the value that a quantity has due to its position in the field. For example, in an electrical field, the magnitude of the field is defined as the force per unit of charge:

$$\vec{E} = \frac{\vec{F}}{q}$$

⁵ Coulomb's law describes the electrostatic force between two charges. These charges experience forces in an electric field = $F = k \frac{q_1 q_2}{r^2}$ where r is the distance between the charges.

⁶ See Science Module 1, Unit 1 topic 2: force for a discussion of the use of an electroscope to detect and measure electrical force.



Topic 1 – Forces And Fields

Notice that **E** and **F** are vectors and have both magnitude and direction. The scalar q , is the magnitude of a tiny test charge. **E** will describe the direction of the force acting on q as well as its magnitude. The magnitude will indicate the strength of the field.

Vectors Can Represent Fields

A field is a region where motion is caused by forces at a distance. An object or particle will change its position when it is placed in a field that contains forces that will attract or repel it. A vector in a field will have three dimensions corresponding to the x , y , and z axes of a three dimensional coordinate system.

Gravitational Fields

These fields surround every material object. Every material object exerts a gravitational force. On the earth objects have gravitational potential energy based on their position in the earth's gravitational field.

Gravitational potential energy = weight x height⁷

and since weight = mg (mass x acceleration due to gravity on earth), or mass x 9.8 meters/s²,

Gravitational potential energy = mgh

Gravity is a universal force that can be measured as an attraction between any two masses that is proportional to the product of the masses, and inversely proportional to the square of the distances between them. The force due to gravity is expressed in an equation similar to that for force due to electric charge in a field:

$$F = G \frac{m_1 m_2}{d^2}$$

G is a very small constant, about $6.7 \times 10^{-11} \text{ Nm}^2/\text{kg}^2$.

Electric Fields

Electric fields are due to any charge (+, or -) or group of charges. They are represented by lines of force. The closer together the lines of force, the stronger the field. A test object with a charge (q) will have potential energy in an electric field because it will be acted on by a force that can change its position. The potential energy per unit of charge in an electric field is the electric potential, V , measured in volts. Voltage is the potential energy due to the position of a charge in a field.

$$V = \text{Potential Energy} \div q$$

The magnitude of an electric force (of attraction or repulsion) is given by an equation that, like gravity, relates the strength of the electric force to the product of the charges divided by the square of the distance between them:

$$F = k \frac{q_1 q_2}{r^2}$$

.....

⁷ Acceleration can produce the same effect as a gravitational field.



Topic 1 – Forces And Fields

Magnetic Fields

Iron filings sprinkled on a paper above a bar magnet illustrate the lines of force in a magnetic field. The filings are most dense where the magnetic field is strongest. Magnetic fields surround magnets.⁸ The earth has a magnetic field with lines of force that allow a compass to point to the magnetic south pole. The magnetic south pole, which attracts the north pole of a magnetized compass needle, is in Northern Canada about 1500 km from the geographic north pole. Magnetic fields are caused by moving electrical charges. Magnetic fields can be induced from electric currents.

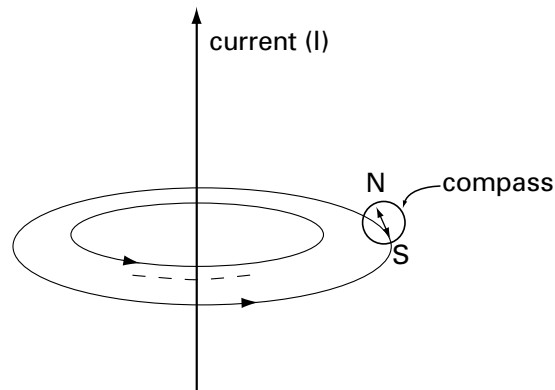

This diagram shows the direction of current in a wire. The current produces a magnetic field as evidenced by the movement of a compass needle. The circular vector lines show the direction of the magnetic field from "south" to "north" (magnetically speaking – not geographically). A right hand rule is used to remember the direction of the magnetic field induced by a current through a wire. If you imagine grabbing the wire with your right hand and with thumb extended in the direction that the current is flowing, then your fingers will represent the circular direction of the magnetic field lines that surround the wire.

⁸ See Science Module two for a discussion of magnetic lines of force and the use of compasses to identify the direction of the lines of force in a magnetic field.



Unit 1 – Matter and Motion

UNIT 1

Topic 2 – Velocity and Acceleration

Motion can be studied from two points of view: descriptions of moving objects that tell us how fast, how long, and in what direction something moves, (**kinematics**), and explanations for motion that involve the forces that cause motion (**dynamics**). Here we look at velocity and acceleration from a descriptive point of view. Topic 3 will cover the dynamics of motion (forces and causes) that you need to know. Topic 4 will apply the analysis of force and acceleration to uniform circular motion.

Velocity And Acceleration Are Vectors

Motion and changes in motion are described with vectors because these quantities have both magnitude (the speed of an object), and direction (which way the object is moving).

Velocity describes changes in position by telling how fast something is moving and in what direction. **Acceleration** describes changes in velocity by telling how fast velocity is changing and in what direction.

Position Vectors Describe Displacement

30 miles east, 2 km 20° east of north, 32 feet downward

Velocity Vectors

30 mph east, 2km per minute 20° east of north, 32 feet downward per second

Acceleration Vectors

30 mph per hour, per hour (= 30 m/h²), 2 km per minute 20° east of north per minute (= 2 km 20° east of north/ minute²), -32 feet per second, per second, (= 32 downward/ s²)

A **scalar** quantity, in contrast, is a number that may have units attached but no indication of a direction. Scalar quantities used in the trades include temperature (degrees), calories (a measure of heat), area (squared units), and volume (cubed units).

Examples of scalar quantities

5 people
5 inches
5 degrees
5 square feet
5 cubic feet

Examples

1. 5 meters per second (5m/s) which means that something is moving at a constant rate of five meters each second, but no direction is specified. This scalar is called the **speed** of an object.

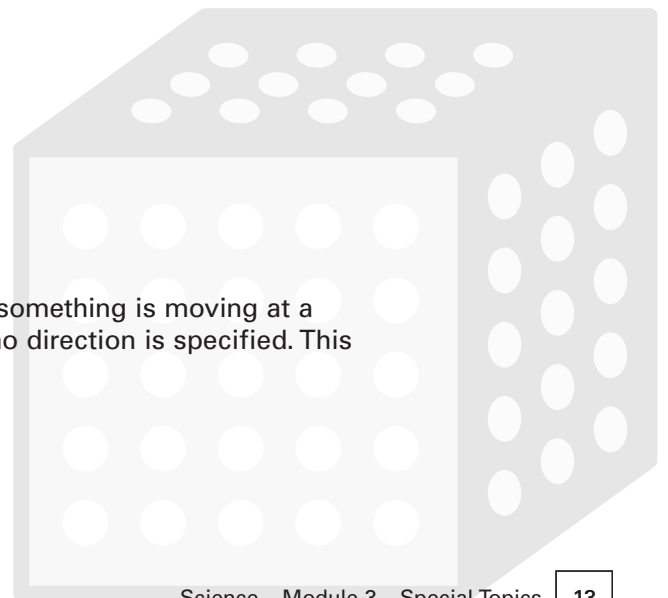



Unit 1 – Matter and Motion

UNIT 1

Topic 2 – Velocity and Acceleration

- 3 miles per second per second (3 miles/second^2) which means that something is going 3 miles per second faster – each second, we know that there is constant acceleration, but no direction is specified. This **scalar describes only the magnitude** of a constant (i.e. uniform) acceleration. The direction of the acceleration is needed to give a complete description because acceleration is a vector.

A vector quantity adds a direction to the size of a number and any units attached to it. Vector quantities used in the trades include force, velocity, and acceleration.

Examples of vector quantities

- 5 inches to the right (displacement)
- 5 degrees clockwise (displacement)
- 5 feet north (displacement)
- 5 meters per second vertically (velocity)
- 5 lbs downward (force)
- 5 feet per second per second northwest (acceleration)

A vector variable is represented by a bold faced letter or a letter with an arrow above it: $\vec{V} = \mathbf{V}$ = velocity (a vector with speed and direction) **example:** the car was traveling 50mph east. $V = 50\text{mph east}$.

Velocity And Speed Are Different

Distance and speed are scalar quantities. The distance traveled by a moving object is called its path and average speed tells us how fast the object travels on its path.

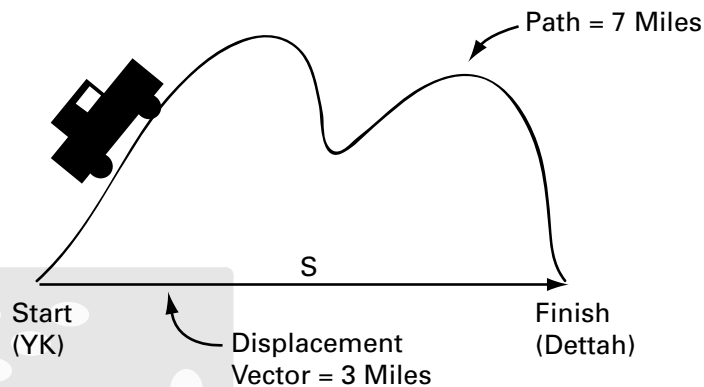

If a car took 10 minutes to go along the 7 mile path above, its average speed would equal distance (ie. Path length)/time = $7/10 = .7$ miles per minute. Notice that this average says nothing about how fast the car was moving at a particular time. It could slow down and speed up on the way. Speed is a scalar quantity, and can be measured as an average over a distance or at an instant. In this example, the direction of the car would be changing all of the time as it follows the curving path.



Unit 1 – Matter and Motion

UNIT 1

Topic 2 – Velocity and Acceleration

In many cases the path may also follow the displacement, but this cannot be assumed, and was not the case in the above diagram. However, the displacement from start to finish in the diagram is 3 miles eastward, 4 miles less than the total distance traveled by the car.⁹ **Velocity is a measurement of the speed and direction divided by the time taken to complete a displacement not a path.** This makes velocity the resultant of the vector addition of all of the components of the path.¹⁰

Velocity is defined in terms of the displacement of an object, not the path taken.

The displacement measures the net change in location from start to finish with the vector \mathbf{s} showing the displacement of 3 miles east. The average velocity (speed and direction) for the displacement is $3/10 = .3$ miles per minute eastward, or in the positive direction on the horizontal (i.e. x) axis. $\mathbf{V} = .3$ miles/minute east.

Another look at displacement:

The displacement of an object in motion is the change in its position when the point of origin is connected to the finishing point by a straight line. The path actually taken can be a curving line or segments that change direction, or a straight line that has the same length as the displacement. The displacement will always measure the distance between start and finish in a line that connects only these two points and tells the direction that points from start to finish. The change in position of an object is measured by its displacement.

Displacement measures a change in position by looking at the result of motion from a beginning point, i.e. the origin of the motion, and an end point, i.e. the final point of the motion. The displacement vector is represented by the arrow connecting these points, with the tail at the origin and the tip at the end of the motion. Average velocity tells us how fast the object was going, on average, and in what direction, to complete the displacement not the path. (Note that in some cases the path will equal the displacement).

⁹ See Math Five, Unit three topic two for examples of the "tail to tip" method for finding displacement (i.e. the resultant vector).

¹⁰ See Math 5, Unit two Vectors, for a discussion of the tip to tail method of adding vectors to get the resultant.



Unit 1 – Matter and Motion

UNIT 1

Topic 2 – Velocity and Acceleration

Conclusion:

The average speed of an object may not equal the magnitude of its average velocity as shown in the last example of a trip from Yellowknife to Dettah. The distance covered by an object will equal its average speed multiplied by the time it takes to cover the distance, but this distance will describe the length of its path, not necessarily the length (i.e. magnitude) of its displacement.

Only when velocity is uniform, i.e. constant, will the instantaneous velocity be the same as the average velocity, and likewise for acceleration: only when the acceleration is uniform will the instantaneous acceleration equal the average acceleration. In this unit we restrict ourselves to considering uniform motion.

Displacement is a vector quantity. The letter **s** is used to represent the displacement vector in many formulas, but **x** is also used to represent horizontal displacement (i.e. displacement on the x axis with + values for displacement to the right, and – values for displacements to the left). **y** can be used to represent displacement on the vertical axis, with + values for upward displacement and negative values for downward displacement.¹¹

¹¹ See Math 5 Unit three topic two for a discussion of the x and y components of vectors and the calculation of resultant vectors.



Unit 1 – Matter and Motion

UNIT 1

Topic 2 – Velocity and Acceleration

Definitions you need to understand:

Distance: the length of a path that is traveled by an object. Distance is a scalar quantity.

Displacement: the length and direction of a line connecting the start point to the finish point of an object's motion. Displacement is a vector quantity that describes a change in position.

Example: a runner in winter goes in a straight line across the lake from Yellowknife to Dettah, his path and his displacement have the same length. The same runner in summer takes a curving path to Dettah following the road. In the summer his path is longer than his displacement. His displacement in summer is the same as in winter, his route has changed, but not the change in his position that results from his trip. Both routes bring him to the same place. Displacement is a net change in position.

Speed: the ratio of distance covered divided by time taken.

Example: 50 mph.

Velocity: the speed and direction of an object.

Example: 50mph north.

Constant or uniform velocity means that the speed and direction do not change with time.

Acceleration: the ratio of a change in velocity divided by the time taken for the change.

Example: 32 feet per second per second (32 feet/second²)

Constant, or uniform acceleration, means that velocity continues to change by the same amount over each unit of time. The unit of time is squared to indicate this.

What You Need To Know:

1. The **average velocity of a displacement** will equal the displacement vector divided by the time taken to complete the displacement. The elapsed time will be equal to the difference between the time at the finish and the time at the start of the motion. Velocity is the rate at which the position of an object changes:

$$\bar{V} = \frac{s}{t}$$

The bar over the vector **V** means that this is the average velocity not the instantaneous velocity. The letter **t** represents the total time taken for the trip. The vector **s** represents the displacement. Unless we are told that the object is moving with constant speed, i.e. speed that doesn't change during the time of travel, we can't know how fast the object is moving at a point of time during its trip.



Topic 2 – Velocity and Acceleration

For example, a car can speed up and slow down during a trip. Only when we know that the motion is **uniform**, i.e. the average speed is constant, do we also know that the instantaneous speed is constant and it will be the same at any point in the object’s trip. **In this special case, the average speed will also be the instantaneous speed.**

Examples of Uniform Motion in Two Dimensions

1. A car travels due north at 55 mph: the direction and the speed are constant, therefore the average velocity = the instantaneous velocity = 55 mph north.¹² In this example the path taken and the displacement have the same length and direction.
2. Let the displacement of a trip have a magnitude of 1 kilometer and the path traveled have a length of 2 kilometers. If it takes the object 3 minutes to complete the path, what is the average velocity?

Using the formula for average velocity we get:

Average velocity = 1 mile displacement / 3 minutes = 1/3 mile per minute eastward.

Be sure to notice that **the time taken to complete the path is the same time required to complete the displacement even though the distances have different magnitudes**. Be sure to notice that the question asks for velocity, and this points at the need to use displacement, *s*, not path length, for the magnitude of the distance.

3. What is the velocity of the object 1 second into its trip?

We can’t answer this question with the information given unless we are told that the motion is uniform and therefore the average speed equals the speed at *t* = 1 second. We also would need to know what direction the object was headed in after one second of travel at a constant speed.

Acceleration

Acceleration happens whenever there is a change in the velocity of an object.

Acceleration happens when there is a change in speed or in direction or both.

Acceleration is expressed as a rate of change in velocity during a time period.

Acceleration is a rate of a rate because it describes how much the rate of change in position (i.e. velocity) changes each second (or other unit of time). Acceleration is a vector quantity. Uniform motion in two dimensions in straight lines will have the average acceleration equal to the instantaneous acceleration, and + and – signs can be used to show direction on the *y* or *x* axis. For simplicity, the vector notation is usually dropped and **a** is used to represent uniform acceleration in two dimensions. The formula for acceleration is:

$$\text{Acceleration} = \frac{\text{Change in velocity}}{\text{Time to make the change}} = \frac{v_2 - v_1}{t_2 - t_1} = \frac{\Delta v}{\Delta t}$$

¹² When motion is not uniform, i.e. speed and direction change, the motion is not along a straight line. The instantaneous speed at a point will equal the limit of distance/time taken as the interval of time approaches zero.



Unit 1 – Matter and Motion

UNIT 1

Topic 2 – Velocity and Acceleration

A falling object or a car slowing down will have negative acceleration. The Greek letter delta is used to represent a change in a quantity.¹³ The final velocity minus the initial velocity is divided by the time taken to accelerate from the initial velocity to the final velocity. This gives the average acceleration, and also the acceleration at any moment when acceleration is uniform.

Velocity is related to acceleration by the fact that final velocity will equal the rate of constant acceleration, a , times the time it takes to reach the final velocity.

$$v_f = at$$

Another useful equation to find the distance an accelerating object travels after a period of time when it starts from rest is

$$d = \frac{1}{2}at^2$$

The above definitions and examples lead to four equations that summarize the relationships you need to understand in uniformly accelerated motion along a straight line:

$$s = vt$$

$$s = v_0t + \frac{1}{2}at^2$$

$$v = \frac{1}{2}(v_f + v_0)$$

$$v_f = v_0 + at$$

In many problems, acceleration starts from rest and the original velocity is therefore 0. This makes the second equation $d = \frac{1}{2}at^2$ when motion starts with an object at rest. Notice that d and s refer to the same quantity, both represent the displacement.

Another equation, derived from the above, eliminates time as a variable.

$$v_f^2 = v_0^2 + 2ax$$

This equation is useful in connecting the horizontal and vertical components of projectile motion because they each take the same amount of time to reach a final velocity of 0.

Example

When an object is thrown upward into the air at an angle, the path it takes is the result of two forces that act on it: the force of gravity that accelerates it towards the earth, and the force of the throw, which has a horizontal component as well as a vertical component that opposes the force of gravity. The horizontal component is constant and obeys Newton's first law. The vertical component keeps changing, and will be the result of combining the negative rate of acceleration due to gravity and the positive rate of vertical acceleration given by the force of the throw over time.

¹⁴ The limit of $\frac{\Delta v}{\Delta t}$ as Δt approaches 0 is the instantaneous acceleration. Likewise for velocity, the limit of $\frac{\Delta s}{\Delta t}$ as Δt approaches 0 is the instantaneous velocity.



Unit 1 – Matter and Motion

UNIT 1

Topic 2 – Velocity and Acceleration

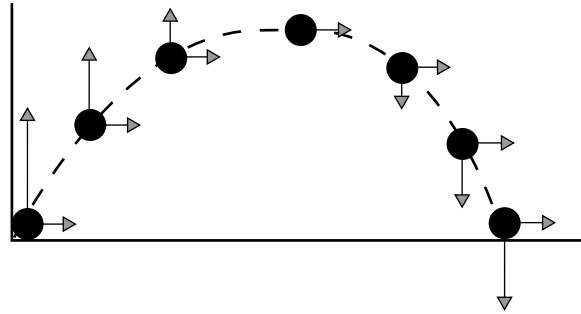

You can see how the vertical component of the velocity of the object decreases on the way up, and increases on the way down while the horizontal component stays constant. If there were no force of gravity, the object would travel in a straight line indefinitely, until opposed by another force. Projectile motion in outer space is an example.

When solving problems, list the variables that you have values for and select the formula that will solve for the variable you need to know.

Examples

1. Falling objects are accelerated by the earth's gravity at the rate of about 9.8 meters per second per second, or 9.8m/s^2 . If an object is dropped and falls for three seconds, what will be its velocity at the end of the third second? What will be its acceleration at the end of the third second?

Answer

A rate of acceleration tells us how much the velocity changes each second. The rate of change is constant, i.e. 9.8 meters is added each second to the velocity of a falling object. This means the object will be traveling with a velocity of 9.8 m per second at the end of the first second, $9.8 + 9.8 = 19.6$ meters per second at the end of the 2nd second, and $9.8 + 19.6 = 29.4$ m per second at the end of the third second.

Notice that the velocity of the object changes constantly and will be increasing each instant. Notice also that the distance traveled during each second will also increase. In the first second the object will fall 4.9 m based on any of the equations for displacement for uniformly accelerated motion:

$$s = v_0t + \frac{1}{2}at^2$$



Unit 1 – Matter and Motion

UNIT 1

Topic 2 – Velocity and Acceleration

The same equations can be solved for any value of t . At $t = 2$ seconds, the distance traveled by the object since the beginning of its fall will be 19.6 m.

At the end of the third second the object will be 44.1 m below where it started. Use the equations to prove this to yourself.

If we wanted to know how far the object fell between seconds one and two, we could subtract the distance covered in the first second, 4.9 m, from 19.6 m (the distance traveled during the first two seconds) to get 14.7 m. Using the same approach we would find that the object fell 24.5 m = 44.1 m – 19.6 m during the third second. Make a sketch to show these distances to scale and you will get a better understanding of accelerated motion.

The acceleration is constant and doesn't change, so the acceleration will still be 9.8 m/s^2 at the end of three seconds.

The formula for final velocity can be used to find the velocity after 3 seconds.

$$v_f = v_0 + at$$

The original velocity is zero, therefore final velocity = $0 + 9.8 \times 3 = 29.4 \text{ m/s}$.

2. A dog team starts from rest and accelerates 3.0 m/s^2 . How far down the trail will it be after 3 seconds? What will be its speed after 3 seconds?

Answer

We are given $a = 3.0 \text{ m/s}^2$, and we need to find s after 3 seconds, and the magnitude of \mathbf{v} after 3 seconds.

$$d = \frac{1}{2} at^2, \text{ so } d = \left(\frac{1}{2}\right)(3 \text{ m/s}^2)(9 \text{ s}^2) = 13.5 \text{ m down the trail.}$$

Notice that you get the same result using $s = v_0t + \frac{1}{2}at^2$ because at rest $\mathbf{v}_0t = 0$.

To find the final speed, use $\mathbf{v}_f = \mathbf{v}_0 + at$, then $\mathbf{v}_f = (3\text{m/s}^2) \times 3 \text{ seconds} = 9 \text{ m/s}$.

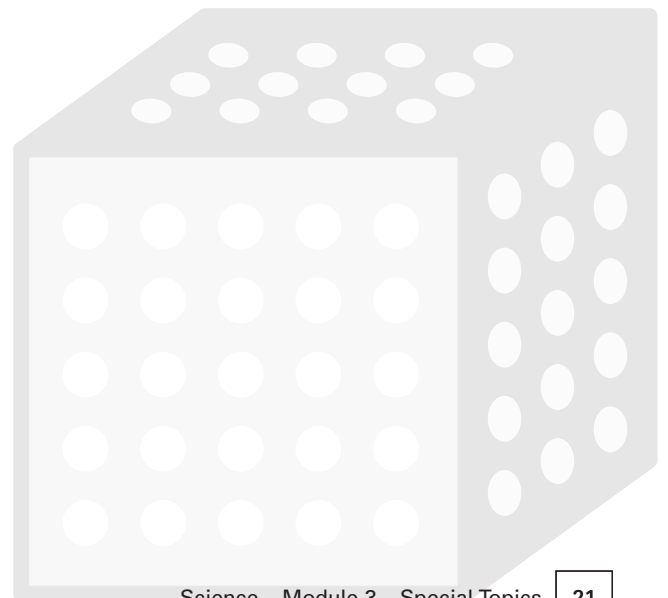



Unit 1 – Matter and Motion

UNIT 1

Topic 2 – Velocity and Acceleration

3. A car accelerates uniformly from rest to 45 mph in 10 seconds. How fast is it going after five seconds? How far has it traveled after five seconds?

Answer

Final velocity = initial velocity + acceleration x time: $V_f = V_0 + at$.

We are given the final velocity = 45mph and told that $V_0 = 0$. This allows us to find the acceleration after we change miles per hour into feet per second for convenience: $(45 \times 5280) \div 60 = 3960$ feet per minute $\div 60 = 66$ feet per second.

Rearrange the equation for final velocity to solve for a:

$$a = \frac{V_f}{t} = \frac{66 \text{ feet/s}}{10 \text{ s}} = 6.6 \text{ feet/s}^2$$

This means that the vehicle is accelerating at a rate of 6.6 feet per second per second. After five seconds:

$$V_f = 0 + (6.6 \text{ feet/s}^2)(5\text{s}) = 33 \text{ feet/s}$$

To find the distance traveled in five seconds use $d = 1/2 at^2$

$$d = (1/2)(6.6 \text{ ft/s}^2)(25 \text{ s}^2) = 82.5 \text{ feet.}$$

4. How long does it take for a stone to fall 100 meters starting from rest?

Answer

The acceleration due to gravity is 9.8 m/s^2 . We know the acceleration, and the distance, use:

$d = 1/2 at^2$ and solve for t

$$100 = (1/2)(9.8)(t^2)$$

$$t = \sqrt{20.408} = 4.5 \text{ seconds}$$

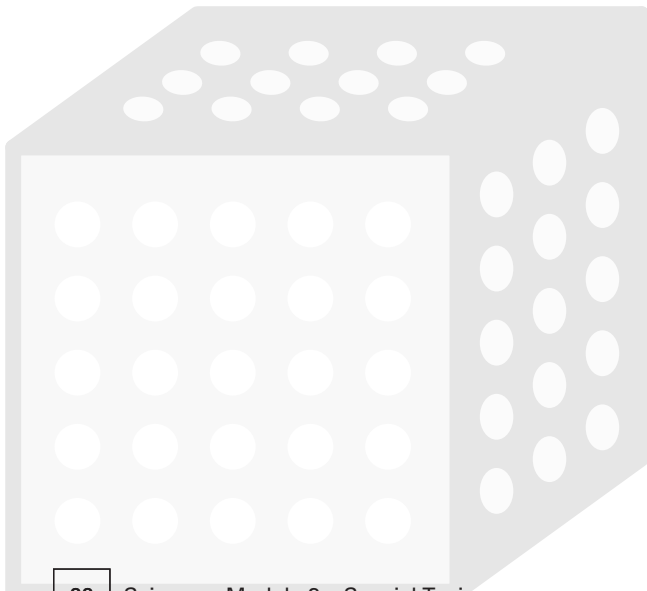



Topic 2 – Velocity and Acceleration

Scale Diagrams and Displacement Problems in two dimensions

An arrow can be drawn to scale to represent a vector. Displacement in two dimensions is a vector and can be represented by vector arrows drawn to scale on paper. For example $\mathbf{s} = 10$ km east can be represented by an arrow that is 5 cm long pointing east if a scale of 1 cm = 1 km is used. When two displacements are added or subtracted the **resultant displacement** can be calculated using scale drawings, or trigonometry and algebra. The resultant is the displacement that connects the starting point to the finishing point.

Problems involving the addition and subtraction of vectors require attention to direction as well as magnitude.

Examples

1. How far is a dog team from its starting point if it travels 30 km east and then 10 km north?

The path traveled has two vector components: first 30 km from A to B, and then ten km from B to C. The resultant displacement, from A to C, is the change in position of the dog team after the trip is over. The line representing the resultant \mathbf{R} measures 10.5 cm which represents 31.5 km. \mathbf{R} connects the starting point to the finishing point and represents the net displacement of the dog team.

This method for finding the magnitude of \mathbf{R} is approximate, and depends on the accuracy of the drawing. If the Pythagorean theorem is used, the exact length (i.e. magnitude) of \mathbf{R} is the hypotenuse and will equal $\sqrt{(30 \text{ km})^2 + (10 \text{ km})^2} = \sqrt{1000 \text{ km}^2} = 31.6 \text{ km}$

Notice that a problem can supply the resultant and ask you to find its components. A scale drawing will allow you measure each displacement vector to find its magnitude by using the scale. Trigonometric methods for resolving vectors into components are discussed in Math 5, unit three.

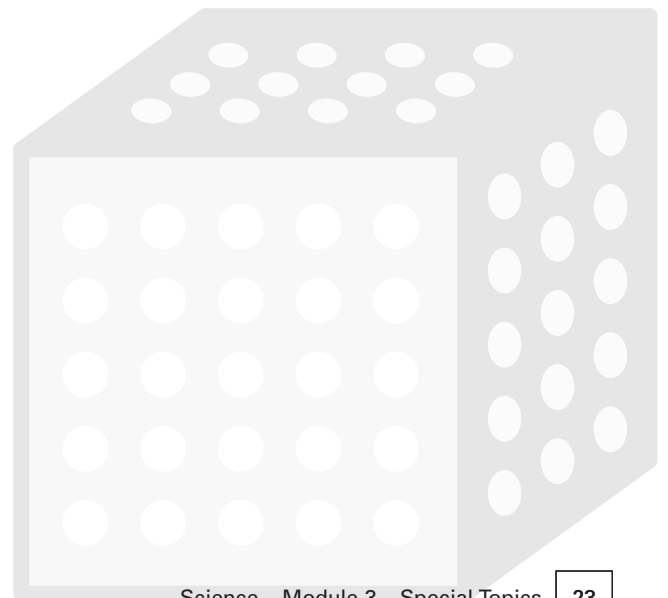



Unit 1 – Matter and Motion

UNIT 1

Topic 3 – Newton’s Laws of Motion

Force is related to the motion of objects by Newton’s three laws. These laws describe the dynamics of motion. Review unit one topics 2,4, and 5 in Science Foundations for a discussion of mass, weight, and gravity. The first law relates mass and weight to a new idea: inertia.

Inertia is the resistance that matter offers to a force that acts to change its motion. Inertia is a property of matter.

The Newton measures the force of gravity on mass (weight)

The attractive force between objects is measured at sea level with metric units for mass. Sir Issac Newton (1642-1727) developed the mathematics to describe gravitational forces. His name has been given to the basic S.I. (international unit) for force, the Newton (N). It takes 9.8 Newtons to lift 1 kilogram from the earth’s surface. The S.I. units of mass are the gram and its multiples: the kilogram, decagram, and tonne. Weight is directly proportional to mass.

You need to remember:

One **Newton (N)** approximately equals the **force** of the earth’s gravity on 100 grams. It takes about 9.8 Newtons to lift 1 kg. **The Newton is a unit of force.**

The gram (g) is an S.I. unit of mass but is also used to describe the weight of 1 cubic centimetre (= 1 millilitre) of water at sea level.

Units of weight are also units of force and
The Newton (N) is an S.I. unit of weight.
The pound (lb) is an Imperial unit of weight.

The harder it is to move an object or change its motion (either direction or magnitude), the more inertia it has. This is true in the absence of friction. It is harder to move a 10 kg mass on the moon than a 1 kilogram mass, just as it is in the greater gravitational field of the earth.¹⁴ Objects in space where there is no gravitational field still have inertia, and will resist changes to motion.

We can understand mass as a measure of how much inertia (resistance to motion) an object has. The tendency of an object to either maintain its state of rest, or to stay in motion in a straight line is called **inertia**.¹⁵

¹⁴ See Science 1, Unit 1, Topic 2: Force, and topic 4: Gravity and weight

¹⁵ See Science 1, Unit 1, Topic 5: Force and motion. Page 40 has illustrations of the first law.



Unit 1 – Matter and Motion

UNIT 1

Topic 3 – Newton's Laws of Motion

The Law of Inertia

An object will continue in its state of rest or of uniform motion in a straight line unless force(s) act on it to change its state of motion.

See page 40 in Science Foundations for an illustration of Galileo's experiment with a ball rolling along paths that approach a straight line to demonstrate that an object will continue in straight line motion indefinitely when there is no friction.

You can thank inertia for the ability to reseal and tighten a loose hammer head by banging the end of the handle down hard on a surface. The handle stops when it hits the surface, but the much more massive metal head continues moving downward until the increasing friction with the tapered head of the handle stops it and tightens the head on the handle.

Practical examples of inertia include flywheels and wrecking balls. A flywheel keeps an engine running smoothly between piston strokes.

The Second Law: $F = ma$, Force = mass x acceleration

This law says that F is the net force acting on an object. This law applies to electromagnetic forces as well as gravitational force. This law indicates that the motion of an object, in particular its acceleration, is caused by the net force acting on it. This force will equal the product of the mass of an object and its acceleration. Notice that when mass is held constant, the acceleration will double when the force does and vice versa. Notice also that if the mass is doubled, and the force is held constant, the acceleration will be halved.

This law connects the description of motion, studied in topic one above, to the cause of motion: force. Notice that F refers to the net force on an object. In modules one and two the net force on an object was calculated as the vector sum of all the forces acting on it. A more precise way of stating the second law is

$$\Sigma F = ma$$

Notice that $m = F/a$. Mass can be thought of as force per unit of acceleration when the equation is in this form and $a = F/m$.

The Third Law: Action and Reaction

Every time an object exerts a force on another object, the second exerts an equal and opposite force on the first. It can be misleading to speak of "reaction" since both forces are equal in this relationship, object a does not react to object b any more than b reacts to a. Each force in the pair is acting on a different object.

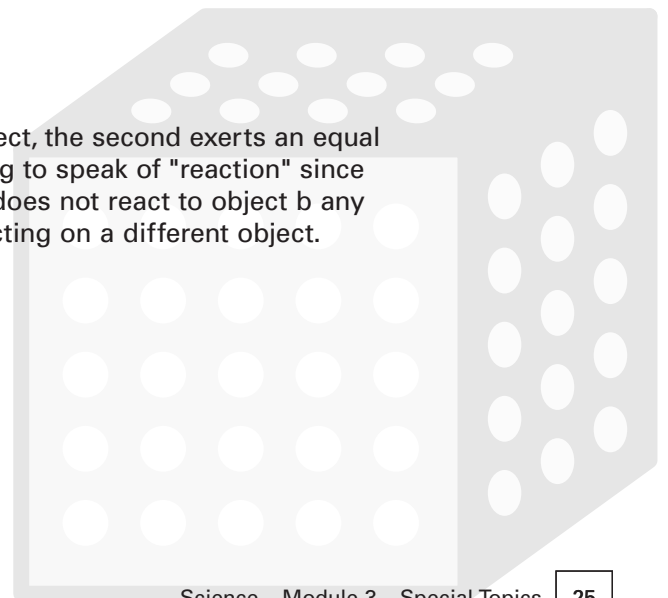



Unit 1 – Matter and Motion

UNIT 1

Topic 3 – Newton's Laws of Motion

Consider the action-reaction pairs in this diagram:

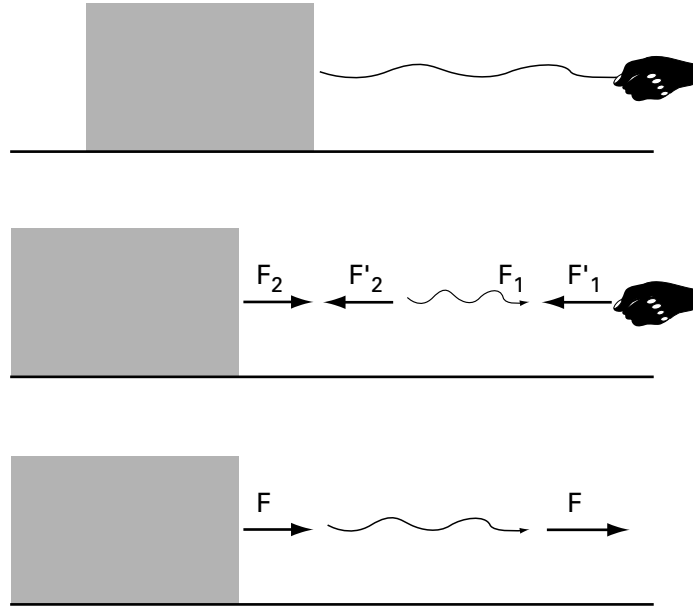

These diagrams show the forces acting on a block and on the person pulling on the rope attached to the block. The block could be moving or not. If it is accelerating to the right, F_1 would be larger than F'_2 . The middle diagram shows the opposed pairs of forces. F_2 is the force of the rope on the block, while F'_2 is the force of the block on the rope. Similarly, F_1 is the force of the hand on the rope, and F'_1 is the force of the rope on the hand. Each pair of opposing forces (acting force and reacting force) nets to 0.

That is, $F'_1 + F_1 = 0$, and $F'_2 + F_2 = 0$.

Be sure to notice that F_1 and F'_2 are not an action-reaction pair, even though they have the same magnitude and act in opposite directions. They act on the same body, the rope. **Action-reaction pairs involve forces that act on different bodies.**

You can experience the third law with a couple of experiments. First push the edge of your hand on a table- the table pushes back with equal force as evidenced by the indent in your hand and the pressure you feel. When you stop running suddenly, you can be aware that you push your feet into the ground and force of the ground back on your feet slows you down.



Topic 3 – Newton's Laws of Motion

Sample Problems

1. What is the mass of a block that weighs 3.00 N at the earth's surface?

We know that the acceleration due to gravity on a mass near the earth's surface is 9.8 m/s^2 . We also know that $F = ma$ and that weight is a force due to gravity.

Therefore $3.00 \text{ N} = \text{mass} \times 9.8 \text{ m/s}^2$ and $\text{mass} = .306 \text{ kilograms}$.

2. How much will a dog weigh in Yellowknife if it has a mass of 12.0 kg?

We are given a mass unit, often confused with weight. Using Newton's second law we know that $m = 12.0 \text{ kg}$ in the equation $F = ma$, and we know that $a = 9.8 \text{ m/s}^2$. Therefore the weight, F , will equal $12.0 \text{ kg} \times 9.8 \text{ m/s}^2 = 117.6 \text{ Newtons}$.

3. An unbalanced force of 100 Newtons acts on a 20 kg mass. What is the acceleration of the mass?

Here we use $F = ma$ where $F = 100 \text{ Newtons}$, and $m = 20 \text{ kg}$. The acceleration = $F/m = 100/20 = 5 \text{ meters/s}^2$.

4. Why do you experience a push sideways when you are in a car traveling around a sharp curve?

The first law explains that you will tend to continue in a straight line unless a force acts to change your direction. Your inertia is being overcome by a sideways force as the velocity (direction) of the car changes. If you sketch the situation you can see that a force that is perpendicular to your motion acts on you when the car turns at constant velocity.

5. 30.5 Newtons accelerates an object to 12.8 m/s^2 . What is the mass of the object?

$F = ma$, and we are given $F = 30.5 \text{ Newtons}$, and $a = 12.8 \text{ m/s}^2$. Notice that the final acceleration is given in the problem and that the value for a in the equation can refer to acceleration at any time.

Solving for $m = F/a = 30.5/12.8 = 2.38 \text{ kilograms}$. Note that the units cancel leaving kilograms when Newtons are expressed in kilogram x meter/ seconds².

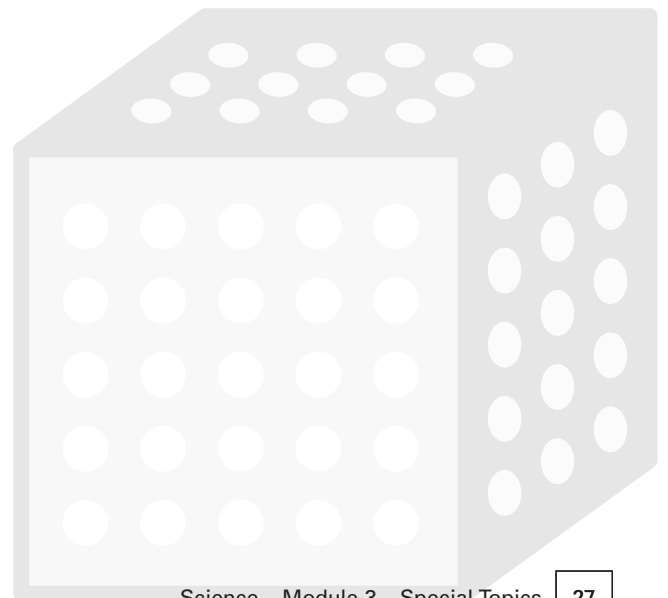



Unit 1 – Matter and Motion

UNIT 1

Topic 4 – Uniform Circular Motion

When an object travels uniformly in a circular path, the motion is the result of component forces that cause acceleration toward the center of the circle. This instantaneous acceleration is called a **centripetal acceleration** and is given by the equation:

$$a_c = \frac{V^2}{r}$$

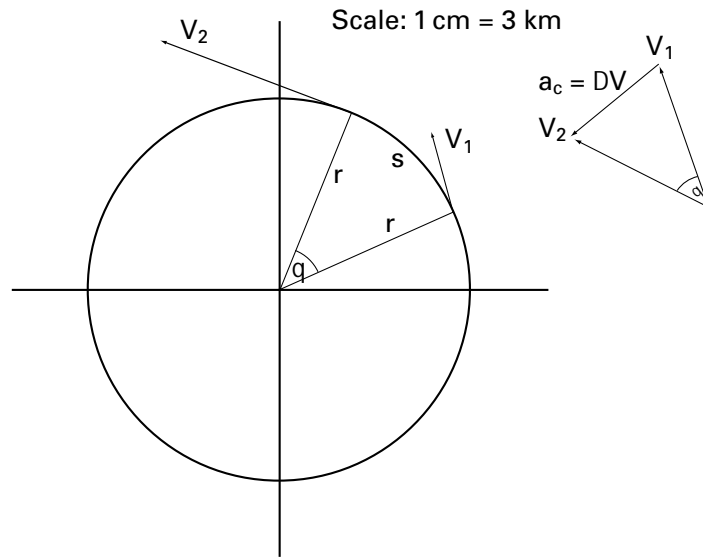

Use this diagram to see how the change in any two velocity vectors of the uniformly moving object add to give the change in the velocity, i.e. the **constant** acceleration toward the center. You can also see that any velocity vector of the object is tangent to the path of the object.¹⁶ Uniform circular motion is the result of two components of two dimensional motion: one component towards the center of a circle, and one component tangent to the circle. This combination (involving vector addition) produces the curving path of the object.

Because the direction of the path (i.e. a circle) is constantly changing, there is acceleration by definition. The direction of the acceleration is towards the center of the circle. When the center is a center of gravity, for example the earth, then an attractive force "pulls" an object away from its straight line motion so that it falls unless there is an equal and opposing force.

If the force of the motion in the direction tangent to the circle is equal to the pull towards the center, the object will continue in a circular orbit. This is what keeps a satellite in a circular orbit.

When the center of the circle is not a center of gravity, for example when a car drives in a circle, or around a curve (part of a circle), then the force towards the center of the circle is supplied by the tires or some other center-directed force coming from the object.

¹⁶ To better understand this diagram you may want to review arc length and trig. in Math – Module 5 – Unit 1, Topic 2 and vector addition in Unit 2.



Topic 4 – Uniform Circular Motion

There is no centripetal "center seeking" force as you can demonstrate to yourself by swinging an object on a rope around in a circle. As you increase the velocity you will feel an increase in the vector that is directed tangent to the circle and you pull harder towards the center (yourself) to keep the object going. If you let go of the rope you will see the object fly off in a direction that is tangent to the circle that it was on.

Planets Are Satellites

Satellites and planets follow circular or near circular (elliptical) orbits due to the result of a gravity vector that pulls them to the center of their orbits. The earth provides the gravitational force for satellites, the sun for planets. The motion of the satellite in a straight line provides the tangent velocity vector to their paths.

The force of gravity varies inversely with the square of the distance between

$$F = G \frac{m_1 m_2}{d^2}$$

objects as found by Newton and expressed in his universal law of gravitation:

This means, for example, that the force of the earth's gravitational field is 1/4 at a distance of 12,800 km from the center of the earth, 1/9 at 19,200 km, and 1/16 at 25,600 km. The velocity needed to keep a satellite in orbit is about 27,000 km per hour at a height of a few kilometers above the earth's surface. With velocity at this magnitude, and this height, the pull of the earth will accelerate the satellite and produce a circular path as the result.

Sample Problems

1. What is the centripetal acceleration of a car that travels around a circular track if the radius of the track is 1000 feet, and the car has a constant speed of 60 mph (88 feet per second)?

The acceleration towards the center of the track is the centripetal acceleration. Gravity is not responsible in this case, and the friction of the tires causes the acceleration. Always express velocity in feet per second and radius in feet in the imperial system, and meters/s and meters in the S.I. system.¹⁷

$$a_c = \frac{v^2}{r} = \frac{7744}{1000} = 7.74 \text{ feet/second}^2$$

We are given $v = 88$ feet/s, and $r = 1000$, therefore:
and the units work out to ft/s^2 . The centripetal component of the velocity vector is 7.7 feet/second².

.....
¹⁷ See Math – Module 4 – Measuring Time, Shapes, and Space, Unit 1 for a review of measurement systems and conversions.

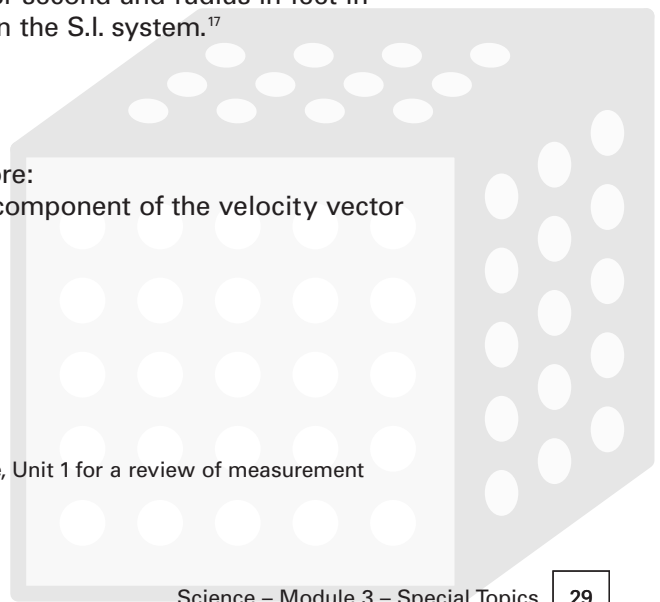



Unit 1 – Matter and Motion

UNIT 1

Topic 4 – Uniform Circular Motion

2. A man swings an object on the end of a rope in a circle (parallel to the ground). The motion is uniform and circular. The centripetal acceleration is $.8 \text{ m/s}^2$. The radius of the circle is 1.5 meters. What is the speed of the object?

Here we are asked to find the magnitude of the velocity at any point. We are given $a_c = .8 \text{ m/s}^2$, and $r = 1.5 \text{ meters}$. Rearrange $a_c = \frac{v^2}{r}$ to solve for v

$$v = \sqrt{a_c r} = \sqrt{(.8)(1.5)} = 1.095, \text{ and the units work out to meters/s.}$$

The object is rotating at a speed of 1.095 meters per second.

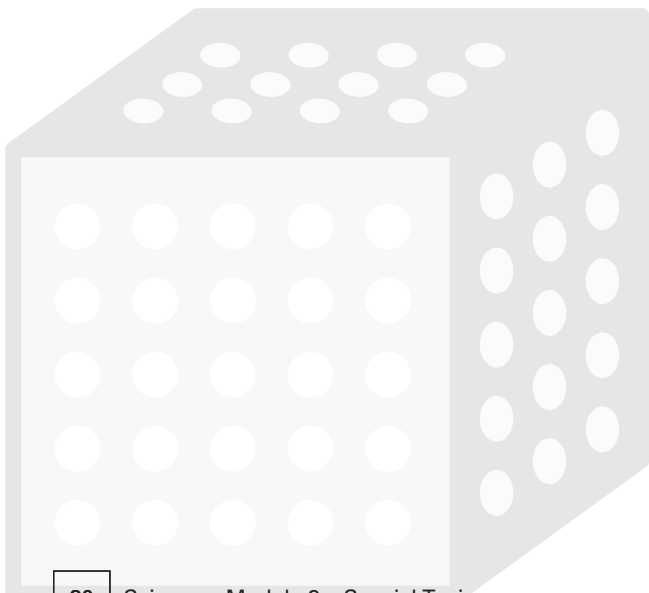



Unit 1 – Matter and Motion

UNIT 1

Topic 5 – Conservation of Momentum

Momentum is the quantity (mass x instantaneous velocity). Momentum is a vector quantity represented by **p**.

$$\mathbf{p} = m\mathbf{v}$$

The units of momentum are kilogram x meters/second, or Newtons per second. A large momentum will be the result of large mass, or velocity, or both. A fast moving car has more momentum than a slow moving one, and will cause more damage in a collision.

A force must be applied to change the momentum of an object. Momentum helps us to understand what happens when force is transferred by a collision between objects because the change in motion that results from a collision depends not only on the magnitude and direction of the applied force, but also on how long the force is applied. Newton's second law can be restated in terms of momentum:

$$\text{Force} = \text{change in momentum} \div \text{time.}^{18}$$

This can be rearranged to show that change in momentum = $F \times t$.

This means that the same effect results from a large force over a short time as for a small force over a long time. When a force acts over a very short time, for example when a baseball is hit, when billiard balls collide, or when a car crashes into a tree, the force can be very large.

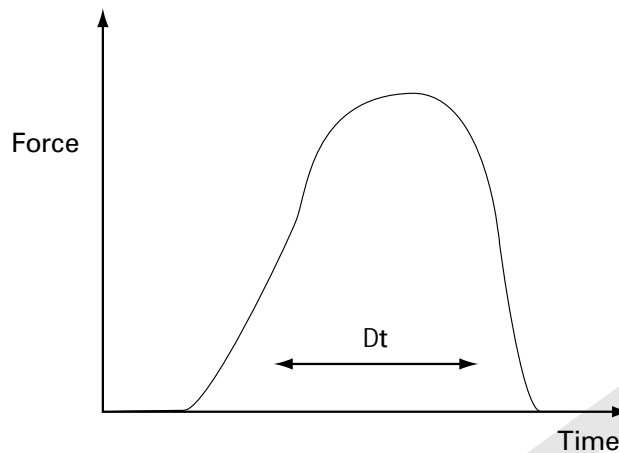

Here the impulse time, t , is very short but the force peaks quickly and drops quickly within the contact period (Δt).

¹⁸ This was how Newton originally expressed his second law, i.e. with force equal to the time rate of change of momentum.



Unit 1 – Matter and Motion

UNIT 1

Topic 5 – Conservation Of Momentum

Impulse is defined as $F\Delta t$, the force vector x the time the force is applied. Momentum is related to Newton's second law and to acceleration by the following equivalences:

$$F = ma = m \frac{\Delta v}{\Delta t} = \frac{m(v_f - v_i)}{\Delta t} \quad (\text{we substitute the definition of } a \text{ for } a)$$

From this we can set

$$F\Delta t = mv_f - mv_i$$

Because each product is already defined as p, we can exchange mv_f for p_f , and mv_i for p_i . Then:

$$F\Delta t = p_f - p_i = \Delta p$$

Momentum is a useful quantity because it is conserved before and after a collision. $F\Delta t$ is the "impulse", i.e. the force x the time it is applied to an object. **The impulse is equal to the change in momentum of the objects involved in a collision.** It says that the force applied over a period of time is equal to the difference between the products of mass x final velocity and mass x initial velocity. This is the law of conservation of momentum.

Conservation of Momentum

The combined momentum of a group of objects will be the same after they collide as before they collide as long as no external forces act.

$$P_f = P_i$$

Sample Problems

1. What is the impulse of this collision: a ball with mass = .15 kg. is pitched in a straight line at 90 m/s. The ball is hit by a batter in the opposite direction with a speed of 110 meters/second.

The formula that defines impulse in terms of momentum will give the answer.

$$F\Delta t = mv_f - mv_i$$

We know $m = .15$ kg and is constant, i.e. the same before and after the collision.

We can factor out m to get:

$$F\Delta t = m(v_f - v_i)$$



Unit 1 – Matter and Motion

UNIT 1

Topic 5 – Conservation of Momentum

But we know the direction of the final velocity vector (the direction after the hit) is opposite that of the initial vector (the pitch). This changes the sign in the equation to:

$$F\Delta t = m(v_f + v_0)$$

We also know that $v_0 = 90$ m/s and $v_f = 110$ m/s, therefore

$$F\Delta t = (.15)(110 + 90) = 30 \text{ kg m/s}$$

2. What is the momentum of a 42 kg. linx running with a speed of 1.5 meters per second?

We use the definition of momentum as the product of mass and velocity:
 $1.5 \times 42 = 63$ kg m/s, or 63 Newtons.

3. What is the velocity of two identical rail cars after they join if they roll toward each other, one at 20 km/h, and one at 5km/h?

Use the conservation of momentum to compare the momentum before and after the collision, since these quantities will be conserved and must equal each other.

Total momentum before coupling = total momentum after coupling.

The masses are equal to each other and can be given a value of $m = 1$ for simplicity. Then:

$$mv_{01} - mv_{02} =$$

$$m(20 - 5) = 2mv_f$$

$$v_f = 7.5$$

The final velocity of the coupled cars will be 7.5 km/hour.

Notice that the coupled cars form one object with mass = 2m, and they will have one velocity after the collision.

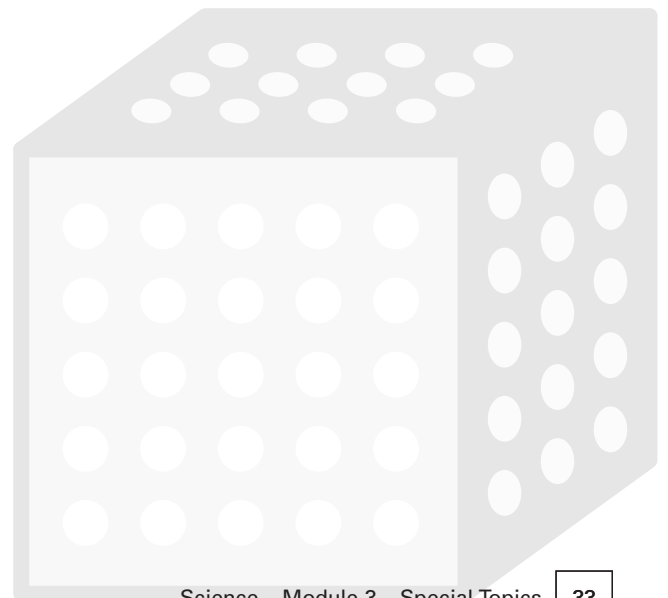

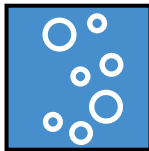

Unit 2

Energy and Work

Topic 1 – Work and Energy

Kinetic Energy

Kinetic energy is the result of motion. Kinetic energy is the energy of particles in motion. Something has to be moving in order for kinetic energy to be measured. Moving objects, particles, and waves, carry kinetic energy. We do not see energy, only its effects.

In contrast, the ability to move, without actually doing so, is called **potential energy**. The relationship between potential energy and kinetic energy is one of storage and release.

For example, gravity is a force that can attract an object. The distance of an object above the earth determines its potential gravitational energy. When the object falls to the ground it releases its stored potential gravitational energy as kinetic energy. A similar description applies to an electric charge in an electric field where the charge has potential energy because of its position in the field that can be changed into kinetic energy as the charge moves to an equilibrium position: ie. where its potential energy is zero.

Kinetic energy is released whenever work is done because a force moves an object through a distance, and this is the physical definition of work. The size of the object and the amount of force can be of any magnitude. When we lift an object and put it on a shelf we are adding to its potential gravitational energy. When an asteroid hits the earth it loses potential energy and gains kinetic energy. After hitting the ground, its kinetic energy is transferred to particles in the ground in the form of heat and motion.



Unit 2 – Energy and Work

UNIT 2

Topic 1 – Work and Energy

Conservation of Kinetic Energy

Kinetic energy cannot be created or destroyed, only changed, stored or transferred into another form of potential or kinetic energy. However, the form of energy becomes less and less useful as it is changed and transferred. Kinetic energy includes "waste" heat energy in all transactions. Entropy is the term from thermodynamics that describes the increasing disorder (inability to do useful work) that results from the wasteful heat energy produced in every kinetic process.

The physical definition of work allows us to connect force with energy. When you think of a contact force, you can think of pushing and pulling an object. A force acts on objects, but may not always succeed in doing work, i.e. in moving anything.

Energy, in contrast, is not something done to an object, but is something exchanged between objects. Energy may be present in an object or process, but still do no work. For example, an object held above the ground has potential energy, but until it is released, no work is done and no conversion of potential into kinetic energy occurs.

Force, like velocity is a vector quantity. It has both magnitude (its size or strength) and direction (the direction in which the force is exerted). In diagrams, force vectors are drawn as arrows with the tail of the vector on the object receiving the force.

Potential and Kinetic energy: The Pendulum

A pendulum is an object allowed to swing on a string. Thinking about what happens when a pendulum moves will illustrate the concepts of force and energy. You can make the following observations:

1. When the pendulum is at rest, it does no work, has no kinetic energy, and has only the potential energy due to its position above the ground.
2. When a force is applied to the pendulum, say by your hand, it can be lifted to a horizontal position. Work has been done on the pendulum because it has been raised the length of the string. As a result it has increased its potential energy in exchange for the loss of kinetic energy delivered by your hand.
3. When the pendulum is allowed to swing, it performs an arc with almost no friction or air resistance. At the bottom of each swing it has maximum kinetic energy, zero potential energy, and at the top of each swing it has maximum potential energy and zero kinetic energy.
4. Work is being done on the pendulum on each swing as the mass of the pendulum bob is moved through a distance. $KE + PE$ is constant, although at each point in the pendulum's journey these quantities will change but always add up to the same total energy.



Unit 2 – Energy and Work

UNIT 2

Topic 1 – Work and Energy

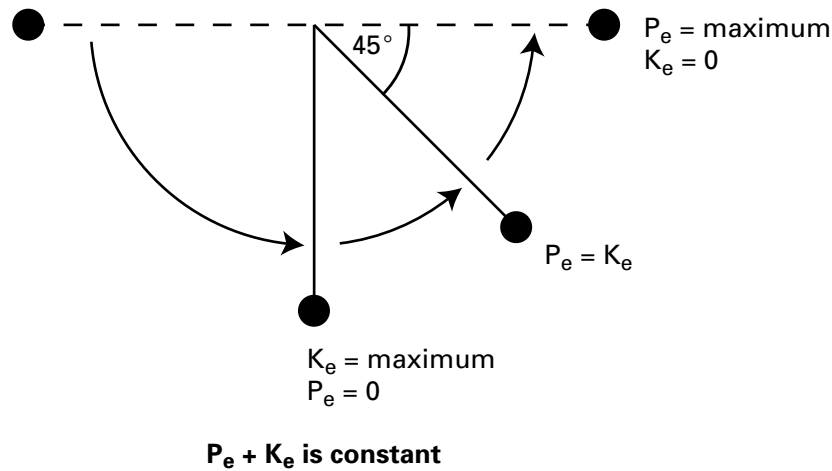

Energy is conserved, kinetic energy and potential energy add up to the same total and all of the formulas noted above will apply.

Energy And Heat: Thermodynamics

Heat is the thermal form of energy. The microscopic kinetic and potential energy of molecules is responsible for exchanges of heat energy, and thermodynamics is the study of heat energy exchanges at any scale we choose. We can observe the same thermodynamic effects in a car engine, in a human cell, in a star, and in an ice cube melting. Energy exchanges always involve losses due to heat, and are never 100% efficient. The total energy remains the same, but heat energy is only useful when there is a difference in temperatures in a system. To understand this, we use the laws of thermodynamics.

The first law of thermodynamics says that the change in the energy internal to a system (ΔU) is equal to the heat added to the system minus the work (W) done by it. Signs of + and - will indicate whether a quantity of heat or work is being added or subtracted from a system. Positive W refers to work done by the system, and positive Q refers to heat added to the system.

The First Law Of Thermodynamics

$$\Delta U = Q - W$$

No exceptions to this law have been found in nature. This law states the principle of the conservation of energy in more precise terms. Heat and work can be measured to determine the change in the energy of a system, for example an engine.



Unit 2 – Energy and Work

UNIT 2

Topic 1 – Work and Energy

The second law of thermodynamics says that heat will always flow from a hotter to a cooler region, and never the reverse. In a hotter region, molecules are moving more quickly than in a cooler region. At the molecular level collisions will average out the energy in a system until everything is at the same temperature.

This is a fact about nature that is not an obvious necessity, because energy would still be conserved if heat flowed from cool areas to hot areas. From a theoretical standpoint, this pattern is possible. The sum of initial energies would still equal the sum of final energies because what is lost by one part of the system would be gained by the other.

The second law describes the direction energy flow takes in our universe, and it has been called "the arrow of time" because all processes flow in the direction described by the second law. Energy will be conserved – but always in one direction. If the reverse were true, we would see rocks rising from the earth, hotter objects in contact with cooler ones becoming hotter and the cooler ones cooler, and broken objects repairing themselves – as appears to be the case in a movie of an object breaking into pieces that runs backwards. When the movie runs backwards we see an increase in order from states of relative disorder.

Entropy is the amount of disorder in a system, and processes in nature tend toward greater and greater states of disorder. (Not the other way around) Put mechanically, **some energy will be unavailable to do useful work in any natural process.**

Examples

1. When different colors of sand are layered in a jar and then shaken, the layers become disordered, and this is predictable. If the jar is shaken continuously, however, the sand will never "reverse" and reorder itself into layers – no matter how much time is spent shaking it. The natural process goes from relative order to relative disorder.
2. When an object breaks after being dropped, we see an increase of disorder. The pieces do not "reverse" and mend themselves.
3. When two objects are put in contact and one is hotter, heat will transfer from the hotter object to the cooler one until they have the same temperature. Here too, order goes to disorder in the sense that two classes of molecules (with different average kinetic energies) have merged into one class with the same average kinetic energy. No useful work could be derived from the objects after their temperatures are the same.
4. A room will tend to get messier and messier – until work is done on it to restore order. Notice that an input of work into this system (the room) to restore order, will be the useful work output of another system that is only 30% efficient due to "heat losses". (The 30% ideal limit is described next).



Unit 2 – Energy and Work

UNIT 2

Topic 1 – Work and Energy

Heat Engines

A temperature difference is necessary to run an engine. Changing mechanical energy into heat energy can be observed when you rub your hands together. To do the reverse and change heat energy into mechanical energy, for example in an internal combustion engine, heat must flow from a higher temperature region (substance) to a lower temperature region. When this occurs, some of the heat can be used to do useful mechanical work. In the case of a car's engine, the higher temperature of the gas that explodes in the cylinder does work by pushing the piston and then being exhausted at a cooler temperature.

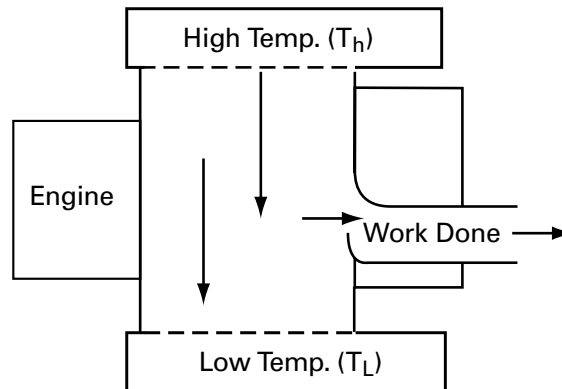

This flow chart shows the gap between the operating temperatures in any engine that is needed to allow work to be done. If the upper and lower temperatures were identical, no work could be done by an engine. For example, in a car engine there would be no pressure difference between the intake and exhaust strokes of the engine. Similarly, if the lower temperature is higher than the upper, there could be no flow of energy in the direction needed to do work.

The best efficiency for a heat engine is directly related to the difference between the operating temperatures. The higher the input temperature, and the lower the output (exhaust) temperature, the more efficient the engine will be. A formula derived by Carnot (1796-1832) uses Kelvin temperature to calculate the maximum efficiency of any heat engine. The best engines designed to date achieve 60 to 80 percent of this ideal value.

$$\text{Maximum Efficiency} = \text{work output} \div \text{heat input} = 1 - \frac{T_{\text{low}}}{T_{\text{high}}}$$

One implication of this is that no machine (i.e. engine) can be designed that will completely change a quantity of heat into work.



Unit 2 – Energy and Work

UNIT 2

Topic 1 – Work and Energy

Example

A steam engine in a power plant is fired by oil. Chemical energy (oil) is converted to heat energy to drive a turbine in the plant. Steam enters the turbine chamber at 400° C, and exhausts at 200° C. What is the maximum possible efficiency this plant can achieve?

Changing the temperatures to Kelvin gives 400°C = 400° + 273 = 673K,
and 200°C = 473K.

$$1 - \frac{T_{\text{low}}}{T_{\text{high}}} = 1 - \frac{473\text{k}}{673\text{k}} = 1 - 0.70 = 30\%$$

This is the theoretical upper limit of what is possible. In reality the plant will achieve at most 80% of this, so the plant will at best 25% efficient.

Force and Energy

Energy is the ability to do work. Matter has the ability to exert force, and this fact connects energy and force with the concept of work. Matter can contain energy because matter has the ability to do work, for example when wood is burned, food is metabolized, or when a sledge hammer hits a stake into the ground. In the case of food, chemical energy is changed into mechanical energy. Any form of energy can be changed into other forms.¹⁹

Energy can also be compared to a fluid that flows between containers but doesn't change its volume because energy is always conserved – never created or destroyed.

Energy can be stored in different places, and in different forms (chemical, thermal, mechanical). When work is done, a force acts on an object to cause movement. Energy will be transferred in this process from one form to another and from one object to another – but no energy is lost or created. This principle is called the **conservation of energy**.

The Kinetic energy of an object is also defined as

$$K = \frac{1}{2} mv^2$$

One half of the mass times the square of the velocity

And,

The net work done on a body equals the change in kinetic energy of the body.

Notice that momentum, mv , is a component in the equation that defines kinetic energy.

¹⁹ Review Science – Module 1 – Foundations.



Topic 1 – Work and Energy

Work = Force x distance

Work is only done when some form of potential energy changes into some form of kinetic energy

Examples:

Solar panels (potential chemical energy changed into electrical energy)

Sling shot: (potential elastic energy changed into mechanical energy)

Pile driver: (potential gravitational energy changed into mechanical energy)

Expansion and contraction involve changes in kinetic energy at the molecular level. The expansion of a solid, liquid or gas occurs when its molecules move faster and cause an increase in volume. Contraction causes a decrease in volume as the molecules slow down and move closer together.²⁰ These changes are also described as changes in **kinetic energy**, or the energy of particles in motion.²¹ The average motion of the molecules in a substance equals its kinetic energy at that time. Changes in kinetic energy cause expansion and contraction that is uniform. Expansion and contraction happen in all directions when the kinetic energy of something changes.

Five Kinds of Kinetic Energy

1. Mechanical Energy

The energy of objects in motion. The amount of mechanical energy being converted from potential energy depends on the mass and speed of the object. When a whole object changes location mechanical energy was required and work was done on the object.

2. Heat Energy

Heat energy is closely related to mechanical energy and describes the random motion of molecules in a substance. The collective motion can be measured as an average amount of molecular motion called its temperature.

When there is a difference in the average temperatures of two connected bodies, a heat transfer will flow from hot to cold. Mechanical energy is changed into heat energy when you rub your hands together with pressure and experience an increase in temperature due to the friction between your hands.

3. Electric Energy

The energy carried by moving charges is electric energy. Positively and negatively charged particles move towards each other to create a neutral, or uncharged state that is stable. A lightning bolt is an example of this. Circuits refer to the movement of electric energy through a conductor.

²⁰ Review expansion and contraction Science – Module 2 – Heat and temperature: expansion, and in the topics on Pressure and the gas laws.

²¹ See Science – Foundations – Unit 1 for the background on the kinetic theory of matter



Unit 2 – Energy and Work

UNIT 2

Topic 1 – Work and Energy

4. Sound energy

Waves carry sound energy. Sound energy is a form of conduction, not convection, because no molecules change position as a result of carrying the wave of energy. Our ears have a membrane (the ear drum) that responds to the movement of nearby air molecules. Sound waves resemble the waves created when two people hold a rope and one person shakes it. The other person received the kinetic energy but the rope's molecules don't change position. This kind of wave is called **longitudinal**.

5. Radiant energy

Radiant energy travels as electromagnetic waves, and can travel in a vacuum where there are no molecules to act as a medium. Light is an example of radiant energy. The sun's energy reaches earth as radiant energy. The electromagnetic spectrum includes low frequency to high frequency waves. Not all are visible to the naked eye.

The Definition of Work

Work is defined in terms of force and distance. In this competency we consider situations where a force is applied to an object over a distance. An object has to move before any work is done according to this definition of work.

Work = force x distance

Work is defined as the product of the size of a force (its magnitude) times the distance over which the force is applied.

Force is measured in weight units, for example, Newtons and pounds. It is important to remember that weight is a measurement of force. Also notice that force has direction in calculations of work. The direction in which a force is applied matters. In diagrams we use an arrow to indicate the direction that a force is applied.²²

Force **vectors** are represented by arrows with the tail drawn on the object that receives the force. A vector is a quantity with both magnitude and direction. An applied force may or may not do work, it depends on whether the force succeeds in moving an object.

Example: Weight is a force vector that is applied in a downward direction.

The output force direction of a machine will often be different than the input force direction, as in the example of a claw hammer removing a nail.

²² See Science – Foundations – Unit 1 on the structure of matter. The force of 9.8 meters/second² (32 feet/second²) is the acceleration due to gravity or g, in the formula for weight = mass x g.



Unit 2 – Energy and Work

UNIT 2

Topic 1 – Work and Energy

The distance traveled by an object that is acted on by a force is measured in feet, centimetres, etc. – and this motion of the object (sometimes called the motion of the resistance, or load) will be in the same direction that an output force was applied.

Work is only done when an object moves in the same direction as an applied force and net work is the work done by the sum of all of the applied forces that act on a object.

Work = force x distance $W = F \times d$

Units of work (W): foot/pounds (ft.lb.) and Newton/metres
And **One Joule = 1 N/m**

Units of force (F): pounds (lb.) and Newtons (N)

Units of distance (d): feet (ft.) and metres (m)

Net Work and Kinetic Energy

Net Work = $F \times d = \frac{1}{2}mv^2 = KE$

Work is connected to kinetic energy. Consider how a car traveling at 80 km/hour has **four times** the kinetic energy of a car traveling 40 km/hour using the formula $KE = 1/2mv^2$. Consequently it will take four times as much work to stop the faster car. Notice that the force that can be applied by a brake based on hydraulic pressure is the same at any speed. This means that the faster car will go four times as far as the slower car before stopping when equal braking pressure is applied.

Do not confuse work with effort

It takes effort to hold a ten pound weight, but as long as the weight is not moving there is no work being done. By using the formula that defines work, we can solve problems for any of the three variables (w, f, and d) when we know the other two. Work is defined in terms of force applied to an object. Work done on the object equals the product of the size of the force (its magnitude) and the distance through which the force acts.



Unit 2 – Energy and Work

UNIT 2

Topic 1 – Work and Energy

Summary

1. **Kinetic energy (KE) =**

Energy transferred by motion = $1/2 \times \text{mass} \times \text{velocity squared}$

$$\text{KE} = \frac{1}{2} mv^2 \text{ units: Newtons, foot pounds}$$

2. **Gravitational Potential energy (PE) =**

stored energy due to position = $\text{mass} \times g \times \text{height}$

$$\text{PE} = mgh \text{ (} g = 9.8 \text{ m/s}^2, \text{ or } 32 \text{ ft/s}^2\text{)}$$

3. **Total energy = kinetic energy + potential energy**

$$E = \text{KE} + \text{PE}$$

$$\text{Therefore: } E = 1/2mv^2 + mgh$$

4. **Net work done equals change in kinetic energy** gained by an object

$$\text{Work done} = F \times d = 1/2mv^2$$

Sample Problems

1. A man pushes a fridge 10m with a force of 50 Newtons. How much work does he do?

We know work is being done on the fridge because the force applied by the man resulted in motion by the fridge. We can solve the formula $W = F \times d$

$$W = 50 \text{ Newtons} \times 10 \text{ metres} = 500 \text{ Newton/metres} = 500 \text{ joules of work}$$

2. A constant force of 12 Newtons is applied to an object and it moves. 60 joules of work were done. What distance did the object move?

We know the amount of work done and the amount of force that was used. We need to find the distance that the object moved in response to the work done on it.

Solve the formula for work ($W = F \times d$) for distance:

$$\text{Distance (d)} = W/F$$

$$\text{Distance} = 60 \text{ joules}/12 \text{ Newton} = \frac{60 \text{ Newton/metres}}{12 \text{ Newton}} = 5 \text{ metres}$$

3. What is the force that was applied to an object that moved 10 metres and had 30 joules of work done on it?

We are given work and distance and need to find force. We solve the formula for work for F :

$$F = W/d$$

$$F = 30 \text{ joules} / 10 \text{ metres} = \frac{30 \text{ Newton/metres}}{10 \text{ metres}} = 3 \text{ Newtons}$$



Unit 2 – Energy and Work

UNIT 2

Topic 2 – Efficiency and Power

Machines can multiply force but they cannot multiply work

What you need to know:

Machines do work – but not for free

$$W_o = F_o \times d_o = f_i \times d_i - W_{\text{friction}}$$

The formula for work allows us to describe machines in terms of the work they do by comparing the products of input and output force times input and output distance. Work must also be done to overcome friction.

$$W_o \text{ work output} = W_i \text{ work input} - W_{\text{friction}}$$

$$F_o \text{ output force} \quad f_i \text{ input force}$$

$$d_o \text{ output distance} \quad d_i \text{ input distance}$$

The work going into a machine must equal the work produced by it. This is an example of the law of conservation of energy. However, in the real world, some of the input work will be used to overcome friction. Only in a perfectly frictionless situation would a machine even "break even".

Efficiency compares work output to work input, or actual mechanical advantage to ideal mechanical advantage.

$$(\%) \text{ Efficiency} = \frac{\text{Work output}}{\text{Work input}} = \frac{\text{AMA}}{\text{IMA}} (\times 100\%)$$



Unit 2 – Energy and Work

UNIT 2

Topic 2 – Efficiency and Power

One formula connects these ideas:

$$\text{Efficiency} = \frac{W_{\text{out}}}{W_{\text{in}}} = \frac{F_o d_o}{F_i d_i} = \frac{F_o/F_i}{d_i/d_o} = \frac{\text{AMA}}{\text{IMA}}$$

For Review:

The Newton measures the force of gravity on mass (weight)

The attractive force between objects is measured at sea level with metric units for mass. Sir Issac Newton (1642-1727) developed the mathematics to describe gravitational forces. His name has been given to the basic S.I. (international unit) for force, the Newton (N). It takes 9.8 Newtons to lift 1 kilogram from the earth's surface. The S.I. units of mass are the gram and its multiples: the kilogram, decagram, and tonne.

You need to remember:

One **Newton (N)** approximately equals the **force** of the earth's gravity on 100 grams. It takes about 9.8 Newtons to lift 1 kg. **The Newton is a unit of force.**

The gram (g) is an S.I. unit of mass but is also used to describe the weight of 1 cubic centimetre (= 1 millilitre) of water at sea level.

Units of weight are also units of force and

The Newton (N) is an S.I. unit of weight

The pound (lb) is an Imperial unit of weight.

Power

Power measures how fast work is being done. You need to understand the definition of work before you can understand the definition of power. **Power is the rate at which work is completed. The same amount of work can be done in different amounts of time.** Power is defined as work divided by the time taken to do the work.



Unit 2 – Energy and Work

UNIT 2

Topic 2 – Efficiency and Power

Power = Work/Time

$P = W/T$

S.I. Unit for power:

Watt = 1 joule/second = 1 Nm/second

Imperial units for power:

Ft.lb/second or

Horsepower: Work/550 x time in seconds or work/33,000 x time in minutes

Horsepower is defined in terms of the work that an average work horse could do in 19th century England. Horsepower is an imperial unit of power. Once again we have a formula with three terms, (P, W, T) and if we know any two we can find the third.

Power calculates how fast work is done

Power = $W/t = Fd/t$

Units: Watts, Horsepower

Sample Problems

1. A bicycle racer does 30,000 joules of work in 200 seconds. Another racer does 25,000 joules of work in 150 seconds. Which racer is more powerful?

This question asks which racer accomplished the most work in the least time. We can answer the question by calculating the power of each racer and then comparing the results to find our answer.

Power = work/time

Power of Racer one = 30,000 joules/200 seconds = 150 joules/second
= 150 watts.

Power of Racer two = 25,000 joules/150 seconds = 166.66 joules/second = 166.66 watts.

Racer two is more powerful by 16.66 watts.



Unit 2 – Energy and Work

UNIT 2

Topic 2 – Efficiency and Power

2. A 70 kg man training for the fire department in Fort Smith takes 90 seconds to climb a ladder that is 4 metres tall. What is the power of the man for the climb?

We first need to calculate how much work the man did when he applied force to lift his 70kg body 4 metres.

$$W = F \times d$$

$W = 70\text{kg} \times 4 \text{ metres} = 700 \text{ N} \times 4 \text{ metres}$ (Note: change kg. into Newtons to get the standard units for work).

$$W = 2800 \text{ Nm} = 2800 \text{ joules}$$

Now use the formula that defines power to find the answer:

$$P = W/T$$

$$P = 2800 \text{ joules} / 90 \text{ seconds} = 31.11 \text{ watts}$$

This man has a power equal to 31.11 watts. His performance can be compared with other members of the fire department by comparing wattage on the same task between people.

3. What is the horsepower of a machine that does 33,000 foot pounds of work in 20 seconds?

Use the formula that defines horsepower. Check that all units are imperial.

$$\text{Horsepower} = \text{work} / 550 \times T(\text{seconds})$$

$$\text{Horsepower} = 33,000 \text{ ft lb} / 550 \times 20$$

$$\text{Horsepower} = 6.6 \times 10^5 / 550 = 1200 \text{ horsepower}$$

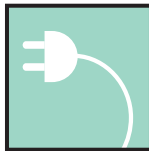

Unit 3

Electricity

Topic 1 – Current, Voltage and Resistance

Background

Electric current is possible because electric charges can flow in matter. Materials that allow an electric charge to flow easily are called **conductors**. Conductors have many free electrons. A conductor will remain electrically neutral (have no net charge) when electrons flow freely through it. When an electron enters a wire at one end, another one leaves from the other end.

Electrostatics

The Coulomb is named for the work of Charles Coulomb (1736-1806). The Coulomb is defined in terms of the basic electric charge carried by the proton (p+) and the electron (e-).²³ Electrostatics is the study of stationary charges.

Electric charge is conserved. When a positive or negative charge is produced on a body, an equal and opposite charge is also produced so that the net charge is zero. In an electrical circuit, the amount of charge entering will equal the amount leaving in one form or another (as heat, current, light, or radiation). In this area you will study the relationships between electrical power, voltage, current, and resistance. The basic idea of conservation is that "what goes in equals what comes out and vice versa."

More precisely, it is really the electric force field that travels through a wire and drives conducting electrons. Energy is what is flowing in a circuit, and at the speed of light (186,000 miles per second). The actual net movement of electrons is much slower. The energy of the electrical field does the work.

An Electric Field

You can find an electric field in the space between two metal plates that are facing each other with a small distance between them when one plate is connected to the positive terminal of a battery, and one is connected to the negative terminal. Any charged particles placed in the space will be moved towards the surface with the opposite charge to that carried by the particle.

.....
²³ e- = -1.6×10^{-19} C, and the amount of charge on each of two objects that will result in each one exerting a force of 9.0×10^9 N on the other is equal to 1 C. Current measures the flow of coulombs.



Topic 1 – Current, Voltage and Resistance

An electric field is defined in the same way as a gravitational field, namely as the force exerted per unit of charge at any point in the field.²⁴ Recall that gravity is a force that is exerted per unit of mass at any point in a gravitational field.

AC and DC

AC stands for "alternating current", DC stands for "direct current". DC stays at a constant value, while AC current reverses direction many times a second. 60 cycles per second or 60 Hz is the frequency of the alternation in Canada, and in much of the world for household current. A sine wave describes the periodic behavior of AC.

Electrical **insulators** are materials with very few electrons free to move. Circuits are continuous (i.e. unbroken) conducting paths. For example, a wire connecting the two terminals of a battery creates a simple electric circuit. If a light bulb is added to the circuit the current will flow from one terminal of the battery through the **resistance** of the bulb and back to the other terminal of the battery. Some of the electrical energy will be given off by the bulb as heat (90%) and some as light (10%). If the wire is cut, not connected, or if a switch is open, the current will not flow and the bulb will not light. The circuit must be closed for current to flow. A circuit will also require a **voltage source**, like a battery, to provide the energy needed to keep the flow of electrons going.

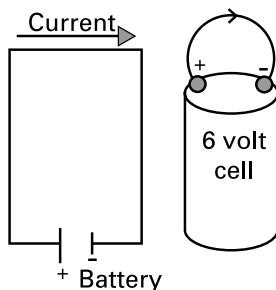

Electric Potential-Voltage

Electrical potential is measured in volts (V). Electric potential is similar to gravitational potential, or to pressure on a fluid. Just as a mass has potential energy in a gravitational field due to its position (height) in that field, so an electric charge has potential energy due to its position in an electrical field. The amount of work that a charge can do based on its position is called its **electrical potential**.

Comparing electricity once again to a flowing river, voltage measures the "electrical pressure" of electric current. An electrical charge will travel from an area of high potential to an area of lower potential just as water will flow downhill, or in the direction of an applied pressure. Voltage measures electrical potential, and a difference in voltage at two points means that there is a difference in electrical potential. **A charge will always seek to move from an area of high potential to an area of lower potential.** It takes work to move a charged particle from an area of low potential to an area of higher potential.

²⁴ Coulomb's law describes the electrostatic force between two charges. These charges experience forces in an electric field. $F = kq_1q_2/r^2$



Topic 1 – Current, Voltage and Resistance

A moving charge will take "the path of least resistance". This is what happens when a lightning bolt strikes the earth, or when a short circuit provides a route for current that avoids resistance. When current flows there is a difference in potential involved.

V = electric potential energy / electric charge

Volts can be expressed in SI units as joules per coulomb.²⁵ Voltage can also be calculated from its relationship to current, power, and resistance. Voltage is measured by a **voltmeter**.

Electrical resistance: Ohms

The Ohm (Ω , Greek letter omega) is the unit that measures **electrical resistance**. It is named in honor of Georg Simon Ohm (1787-1854). Electrical resistance (R) causes a wire to resist the flow of current. Less current will flow through a high resistance wire than a low resistance wire. Electrical resistance can be compared to fluid flow and fluid viscosity.

Electrical power: Watts

Electrical power (Watts) = electrical energy (joules) / time (seconds).

When the current is given in amperes, and the voltage in volts, the power will be in watts. Electrical power is work done per unit of time.

Resistance (resistivity) depends on the kind of material, the temperature, and on the shape and size of the wire.

- a long wire will have more resistance than a short one
- a thick wire (large cross-sectional area) will have less resistance than a skinnier wire (smaller cross-sectional area).
- a hot wire will offer more resistance than a cooler one.

Ohms are calculated from measurements of voltage (V) and current (I)

One Ohm = one volt per amp of current. $1\Omega = 1V/1A$

$$\text{Resistance (ohms)} = \text{Volts/I (amps)}$$
$$R = V/I$$

²⁵ 1 coulomb = the amount of charge on each of two objects that will result in each one exerting a force of 9.0×10^9 N on the other. Current measures the flow of coulombs.



Topic 1 – Current, Voltage and Resistance

Current – Amperes

Compare an electric current to a river current. Although no matter is travelling in an electric current, other points of comparison are instructive. For example, the more water, and the faster it flows, the greater the current. Electric current can be compared to water and is sometimes referred to as "juice".

In the case of moving electric charge, the more charge and the faster it flows the greater will be the electric current. The amount of current is given the symbol "I", and measures the amount of charge flowing per second. This flow rate of charge is defined in terms of coulombs per second.

I = electric current = Charge/time

Example: current flow in a wire

One ampere means that one coulomb of charge is flowing by any point in the wire every second.

I is given in units called **amperes** in recognition for the work of Andre Ampere (1775-1836) (also abbreviated as A, or amp). Electrical current is measured by an **ammeter**. The Coulomb is named for the work of Charles Coulomb (1736-1806). The Coulomb is defined in terms of the basic electric charge carried by the proton (p+) and the electron (e-).²⁶

Conventional current: from + to -

For all practical purposes, positive charge flowing in one direction is equivalent to negative charge flowing in the opposite direction.

Historically, current flow was thought to be from positive to negative and this convention is still used today to describe current flow. The actual direction of electron flow is always from negative to positive because unlike charges attract and electrons do the moving.

²⁶ e- = -1.6×10^{-19} C, and the amount of charge on each of two objects that will result in each one exerting a force of 9.0×10^9 N on the other is equal to 1 C. Current measures the flow of coulombs.



Topic 2 – Circuits

Basic Circuit Concepts²⁷

Circuits are continuous (i.e. unbroken) conducting paths. For example, a wire connecting the two terminals of a battery creates a simple electric circuit. If the wire is cut, not connected, or if a switch is open, current will not flow. The circuit must be closed for current to flow.

In order for current to flow through a circuit, there must be a voltage source to cause the flow of electrons. Electricity only flows when there is a potential difference that is maintained by a source of power, for example a battery. When the battery is "dead" because all of its electrical potential has been used (discharged) the flow of electrons in the circuit will stop.

A circuit can be closed or opened by a **switch**. When the switch is closed the current is able to flow.

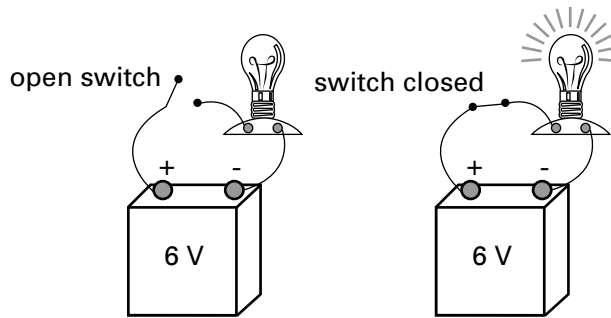

When the battery loses enough of its electric potential through use so that it no longer can overcome the resistance offered by the bulb, the current will stop flowing and the light will go out. Flashlight batteries are sometimes rated by the number of hours they can keep a flashlight bulb lit.

Junctions

Junctions are points in a circuit where three or more connected wires meet. A branch is a part of a circuit between two junctions that contains one or more circuit elements, for example a resistor.

Conservation of Energy in Circuits

The sum of the currents entering and leaving a junction are zero when we assign negative value to the currents leaving the junction. The current in will equal the current out.

Similarly, the sum of voltage rises and drops in a circuit will also equal zero. These two rules, called Kirchoff's rules, apply the principle of the conservation of energy to circuits.

.....
²⁷ You may want to review Science – Module 2 – Unit 5, Electricity for this topic.



Topic 2 – Circuits

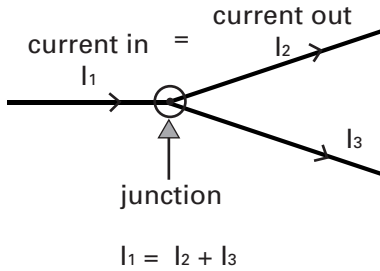

Circuits are Diagrammed

Circuit diagrams are useful ways to show what is happening in an electrical circuit. You need to know the following basics about circuit diagrams

1. A battery is represented by:

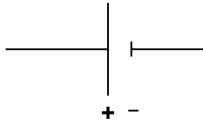

2. A resistance is represented by:



3. An electrical meter is represented by:

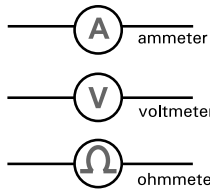

4. Ground is represented by:



5. A switch is represented by:



6. A series circuit looks like this:

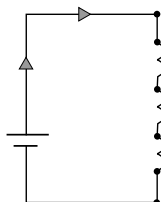



Topic 2 – Circuits

7. A parallel circuit looks like this:

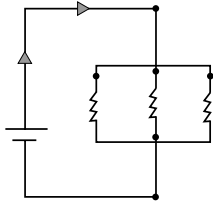

Equivalent Resistances

In a circuit, a single resistance can replace several resistances and have the same effect on current and voltage. In a series circuit the equivalent resistance is R_s and is equal to the sum of the individual resistances.

Example: Series Circuit

In a series circuit with three light bulbs having resistances of 10, 5, and 12 ohms, a single resistance of 27 ohms will be equivalent.

In a parallel circuit the equivalent resistance is R_p and $1/R_p$ (the reciprocal of R_p) is equal to the sum of the reciprocals of the individual resistances.

Example: parallel circuit

in a parallel circuit with a 10 ohm bulb and a 20 ohm bulb, the equivalent resistance will equal the reciprocal of $1/10 + 1/20 = 3/20$, and the reciprocal of $3/20 = 20/3 = 6.66$ ohms.

Series Circuits

Series circuits connect electrical devices, for example light bulbs, in a single conducting path.

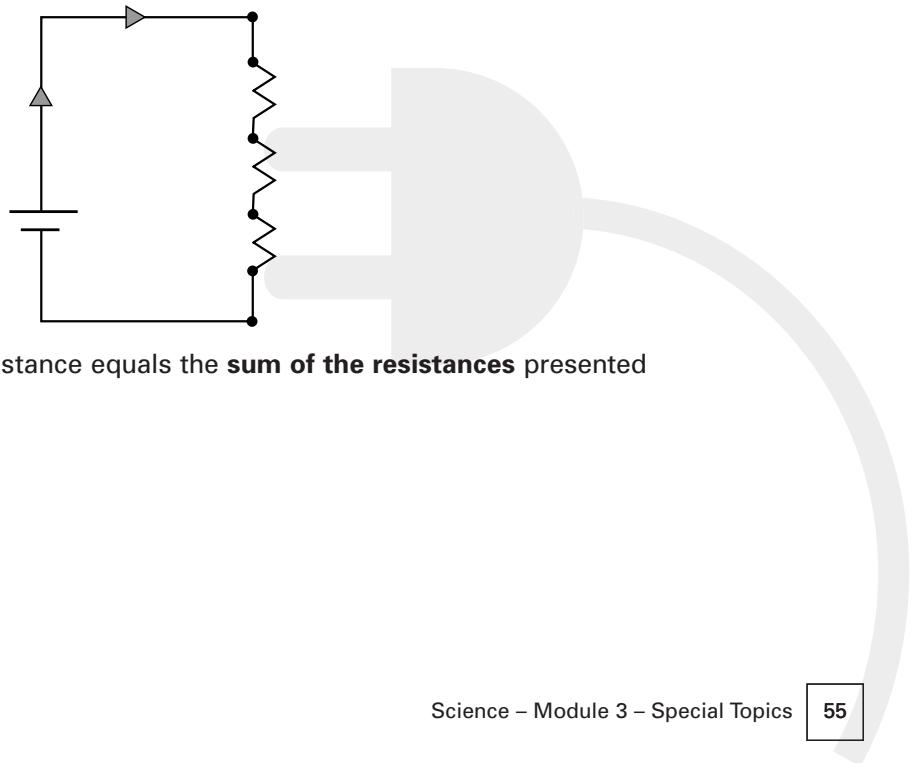

In a series circuit, the total resistance equals the **sum of the resistances** presented by the devices in the circuit.



Topic 2 – Circuits

For series circuits

$$\text{Total or net } R = R_1 + R_2 \dots R_n$$

(R_n is the last component in the circuit)

Series Circuits

Series circuits connect electrical devices, for example light bulbs, in a single conducting path. Bulbs connected to a power source in series will burn less brightly than they would if they are connected to the same source in parallel. In series circuits, the resistances add and less current reaches each bulb. There is a voltage drop between bulbs. The same amount of current flows through each bulb, but with less potential ("pressure") behind it. In a series circuit, the interruption of the circuit at any point will stop the current from reaching any of the appliances on it. If one bulb goes out on a series circuit, all the bulbs will go out.

Series Circuits, What You Need To Know:

1. $R_s = R_1 + R_2 \dots R_n$ (R_n is the last resistance in the circuit)

In a series circuit, the total resistance (R_s) equals the sum of the resistances of the devices in the circuit.

2. $I_s = I_1 = I_2 \dots I_n$

In a series circuit the amount of current (I_s) flowing through each resistance is the same.

3. $V_s = V_1 + V_2 \dots V_n$

In a series circuit, the total voltage "rise" (V_s) is equal to the sum of the voltage drops that occur across each resistance in the circuit.

Bottom line: R and V sum, and I is constant in series circuits.

Sample Problem

Two bulbs are connected in series to a 12 volt battery. One bulb has a resistance of 4 ohms and the other has a resistance of 10 ohms. What is the equivalent resistance? What is the amount of current taken from the battery? How much current flows through each bulb (resistance)? What is the voltage drop across each resistance?



Topic 2 – Circuits

This problem is based on the rules for a series circuit. Begin by writing down these rules.

R and V sum, and I is the same in series circuits

1. $R_s = R_1 + R_2 \dots R_n$
2. $I_s = I_1 = I_2 \dots I_n$
3. $V_s = V_1 + V_2 \dots V_n$

Next write down what is given in the problem:

$V_s = 12$ volts (the battery has an electric potential of 12 volts). This is the total voltage put into the circuit. The total voltage drop over the resistances will also equal 12 volts.

$$R_2 = 4 \text{ ohms}$$

$$R_n = 10 \text{ ohms}$$

Now tackle each question in the problem.

- a) What is the equivalent resistance?

The equivalent resistance is defined as the single resistance that will have the same effect (resistance) as the individual resistances taken together. In a series circuit $R_s = R_1 + R_2 \dots R_n$ in our case $R_s = 4 + 10 = 14$ ohms.

- b) What is the amount of current taken from the battery?

This will equal the total current taken by the two resistances of 4 ohms and 10 ohms. In a series circuit,

$$I_s = I_1 = I_2 \dots I_n$$

The current across each resistance will be the same. Notice that the voltage will be different across each resistance from the full 12 volt potential offered by the battery. To find I anywhere in the circuit we can use total I, total V and total R. We need to look at the circuit using the equivalent resistance for all of the individual resistances. Then we can use $V = IR$ for the total circuit:

$$12 \text{ volts} = I \times R_s = I \times 14 \text{ ohms}$$

$$I = 12 \text{ volts} / 14 \text{ ohms} = .86 \text{ amps}$$

- c) How much current flows through each bulb (resistance)?

Because this is a series circuit the amount of current is the same for each resistance and for the total current passing through the circuit. This was calculated above as .86 amps.



Topic 2 – Circuits

d) What is the voltage drop across each resistance?

In a series circuit $V_s = V_1 + V_2 + \dots V_n$

We are given $V_s = 12$ volts, and we have calculated I throughout the circuit = .86 amps. We also know that the voltage drop over each resistance can be found by applying $V = IR$ to each.

We know $R_1 = 4$ ohms and $R_2 = 10$ ohms, therefore:

V_1 (the drop across R_1) = .86 amps x 4 ohms

$V_1 = 3.44$ volts

And $V_2 = .86$ amps x 10 ohms = 8.6 volts

We can see that the sum of these drops equals 12 volts as expected by the conservation of electrical energy in a circuit.

Parallel Circuits

In a parallel circuit each device is connected directly to the power source. The current from the power source is divided between the resistances in the circuit. In a parallel circuit, 1 divided by the total resistance (net resistance) equals the **sum of the reciprocals of each resistance** presented by the devices in the circuit.

$$1/R_{\text{total}} = 1/R_1 + 1/R_2 + \dots 1/R_n$$

Bulbs in parallel will each burn with the same brightness, there is no drop in electric potential from one bulb to the next because they each have a direct input from the source. Each bulb will get the same voltage. Houses are wired in parallel circuits so that each device will receive the same voltage, (120 V in Canada). One light can be turned off, but all the lights in the house don't go off with it.

Memory Tip:

PRR + "in parallel circuits resistance reciprocals add to give the reciprocal of the total resistance".

Remember to "purr".

In a parallel circuit each device is connected directly to the power source.

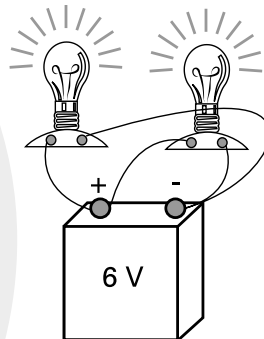



Topic 2 – Circuits

In a parallel circuit, the reciprocal of the total resistance (net resistance) equals the **sum of the reciprocals of each resistance** presented by the devices in the circuit.

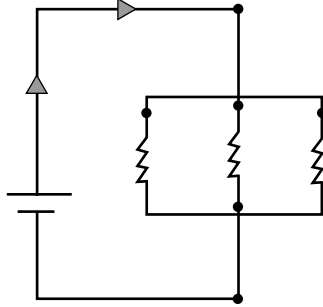

$1/R_p$ equals the sum of the reciprocals of the resistance of each component

$$1/\text{Total or net } R_p = 1/R_1 + 1/R_2 + \dots 1/R_n$$

Sample Problem

Two resistances are in a parallel circuit. The total resistance is 2 ohms, and one resistor is 6 ohms. What is the resistance of the other resistor in the circuit?

We know that the sum of the reciprocals will equal 1 divided by the total. Plug in the values we are given and solve this equation:

$$1/2 = 1/6 + 1/R_2$$

$$1/3 = 1/R_2$$

$$R_2 = 3$$

This circuit has two resistances, one 3 ohms and one 6 ohms to produce a total resistance of 2 ohms.

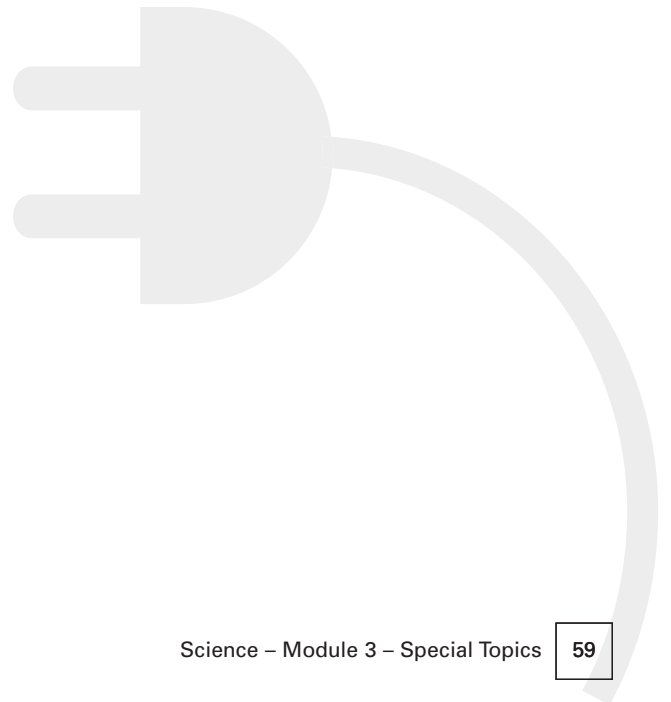



Topic 3 – Electrical Power

Electrical Power: Watts

Electrical power (Watts) = electrical energy (joules) / time (seconds).

When the current is given in amperes, and the voltage in volts, the power will be in watts. **Electrical power is work done per unit of time.**

Electrical energy is converted to heat and light energy by appliances that use materials that resist electric current. For example, plug in electrical heaters, frying pans and light bulbs. Each conversion process can be expressed as work divided by time. Power ratings on appliances are given in watts or in terms of voltage and current that can be related to power by **$P = IV$** .

1 kilowatt hour (kWh) = the energy used at the rate of 1000 watts per hour.

1 kWh = 1000 joules/second \times 3600 seconds/hour = 3.6×10^6 joules.

Watts measure the amount of electrical energy that is transformed in a period of time. Electrical power is calculated by the amount of energy in joules that is used every second.

Electrical power is related to current (I) and voltage (V) by this formula: **$P = IV$** .

Key relationships

Ohm's law

1. Current (I) is directly proportional to voltage (V)

therefore:

2. $V = IR$ (voltage = current \times resistance)

3. $P = IV$ (power (watts) = current times voltage)

a) $P = I^2R$ (because $V = IR$, substitute IR for V in $P = IV$)

b) $P = V^2/R$ (because $I = V/R$ from $V = IR$, substitute V/R in $P = IV$)

One equation says it all:

$$P = IV = \frac{V^2}{R} = I^2R$$



Topic 3 – Electrical Power

Cost of Electrical Energy Calculations

Electrical power can be calculated and costs are based on power consumption. Watts measure the amount of electrical energy that is transformed in a period of time. Electrical power is calculated by the amount of energy in joules that is used every second. Watts measure the rate of power consumption.

Electrical power (Watts) = electrical energy (joules) / time (seconds). When the current is given in amperes, and the voltage in volts. The power will be in watts. One joule per second = one watt (W).

1 kilowatt hour (kWh) = the energy used at the rate of 1000 watts per hour.

Costs are calculated by multiplying the number of kilowatt hours times the price per kilowatt hour.

Sample Problems

1. How much would it cost to run a 100 watt light bulb for 20 hours, if it costs \$.10 per kWh?

We are given the cost per kWh, the wattage (rate of consumption) of an appliance (the bulb), and the length of time it will operate. We need to find how many kilowatt hours of energy the bulb will use in 20 hours. First, convert watts to kilowatts: 100 watts = .1 kW. The bulb will use .1 kWh each hour that it is on. 20 hours means it will use 2 kWh. (.1kW x 20 hours). Each kilowatt hour costs \$.10, and we have two kWh, so the cost will be \$.20 (.1 x 20).

2. How much will a frying pan cost to operate for 1.5 hours if it is rated at 1600 watts and 1 kWh costs \$.20?

We are told that this appliance will use 1600 watts every hour, therefore it will use 2400 watts, or 2.4 kWh in a 1.5 hour period. Each kWh costs \$.20, so the cost will be .20 x 2.4 = \$.48

Alternatively, simply write out the relationship this way:

$$1.6\text{kW} \times 1.5 \text{ hours} \times \$.20/\text{kWh} = \$.48$$

3. What is the power consumption of an electric drill that is rated at 120 volts (AC) and 1.4 amps? What will it cost to run the drill for 3 hours at a cost of \$.20 per kWh?

We will use the relationship $P = IV$ to calculate the power in watts. $I = 1.4$, and $V = 120$, therefore $P = 168 \text{ W}$. This drill will use 168 watts of electrical energy each hour. In ten hours it would use 1680 W or 1.68 kWh.

In three hours the drill will use $3 \times 168 = 504 \text{ W}$. About one half kWh is used in three hours of operation. One kWh costs \$.20, so $504/1000 = .504 \text{ kWh}$
@ \$.20 = \$.1008



Unit 3 – Electricity

UNIT 3

Topic 3 – Electrical Power

Load Calculations

Load is the amount of current that is drawn from a source. When too much load is drawn through a circuit, the wires can heat up and cause a fire. This is why fuses and circuit breakers are used to protect wiring in buildings. Heat in a circuit = I^2R , sometimes referred to as "joule heating". When there is too much current, and/or a large resistance, the power being consumed will cause dangerous amounts of heat. Overloading happens when a wire carries too much current.

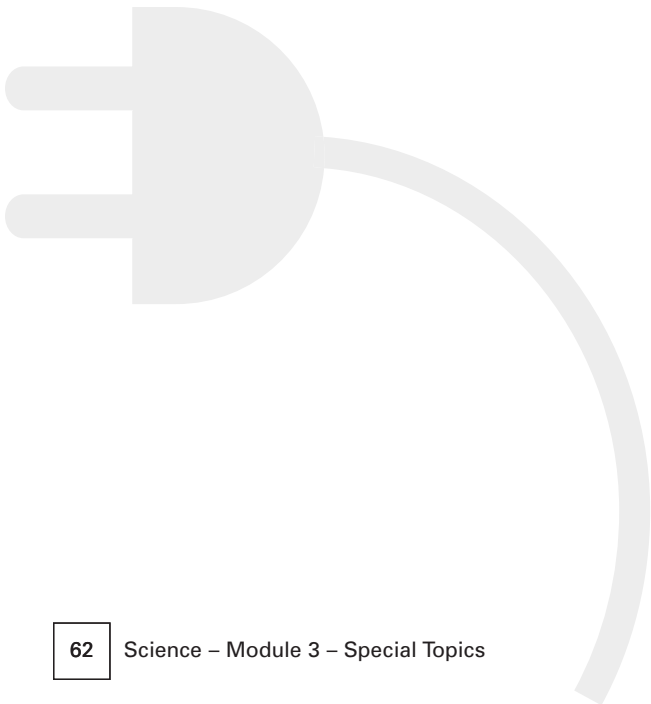



Topic 4 – Transformers

A transformer uses magnetic induction to increase (step up) or decrease (step down) alternating current voltage. As discussed in Science Module Two, a voltage is induced in a loop of wire when a magnet moves up and down in it. A current can be produced from a changing magnetic field.

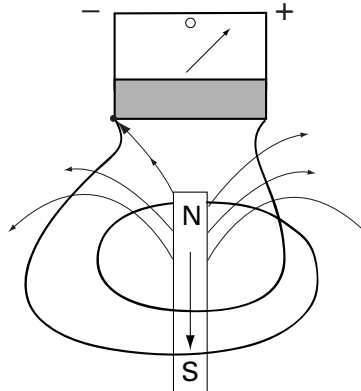

A changing magnetic field is the result of moving the magnet up and down. A current is measured only when there is a changing magnetic field.

Transformers apply Faraday’s law.²⁸ Faraday defined flux (f) as magnetic field B x area through which B passes.

$$f = BA$$

The magnitude of the voltage induced in a wire is equal to how fast the flux changes. The total voltage that is induced will be greater if either B , A , or both are increased.

$$\text{Voltage} = \text{number of loops of wire} \times \text{change in flux} / \text{time}$$

Transformers only work with AC current because the current has to change direction to cause a change in voltage in the secondary coil. If dc current is used, the magnetic field will be constant and no voltage will be induced in the secondary coil. A voltage is induced in a loop of wire when the magnetic field through the wire changes.

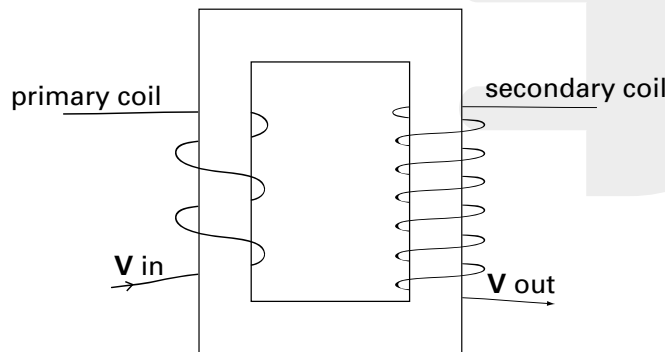

²⁸ These results were studied by Michael Faraday (1791-1867).



Topic 4 – Transformers

In this diagram an iron core links the two coils. An alternating current is applied to the primary coil and causes a magnetic field to change as the current changes. The changing magnetic field will pass through the wire wound on the secondary coil and induce a current. There are more loops of wire in the secondary coil so this will step the voltage up.

The ratio of number of turns of wire in each coil to the ratio of the voltages gives the relationship you need to know:

$$\frac{V_2}{V_1} = \frac{N_2}{N_1}$$

Example

What is the output voltage of a transformer if the primary coil has 20 turns, the secondary coil has 100 turns and the input is 120 v AC?

This transformer will step up the input voltage:

$$\frac{100}{20} = \frac{V_2}{120}$$
$$V_2 = 600$$

The relationship between current and voltage in a transformer is given by the products of the current and voltage for each coil:

$$I_p V_p = I_s V_s$$

Example

what is the current in the secondary coil of a transformer if $V_p = 120$ v, with 20 primary coil turns, and 100 secondary coil turns when a current of 5 amps is put into the primary coil?

$$I_s = \frac{N_p}{N_s} I_p = \left(\frac{20}{100}\right) 5.0 = 1.0 \text{ amps}$$

In electrical power transmission, transformers are used to step up voltage to avoid losses over long distances. Step down transformers are used at the receiving end of the line.



Unit 4

Light

Topic 1 – Electromagnetic Waves

Light is an electromagnetic wave. Electromagnetic energy is carried by electromagnetic waves. Electromagnetic waves are transverse waves as opposed to longitudinal waves.

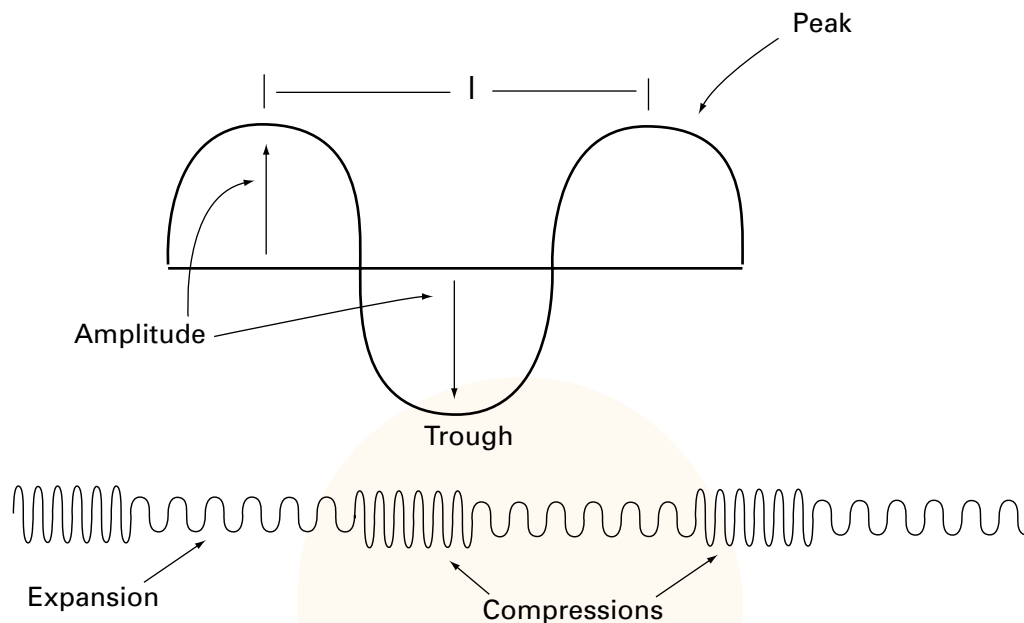

A **longitudinal wave** transfers energy in the same plane as shown above with a slinky. A **transverse wave** travels perpendicular to the particles of the medium carrying it, as shown above. The particles in a rope that is snapped to carry a wave move up and down, but the wave moves straight ahead.

When two waves with the same amplitude and period interact, their amplitudes will double because they are in phase. This is called **constructive interference**. If they have opposite period and amplitude they will cancel each other out in **destructive interference**.



Topic 1 – Electromagnetic Waves

When a wave hits a boundary some of its energy is absorbed and some is reflected. When a wave changes from one medium to another, for example a sound wave from air to earth, or a light wave from air to water, its velocity will change and the direction of the wave may change. This is called **refraction**.

The **Doppler effect** is a special kind of interference caused by motion with or against the direction of a sound wave with applications to other waves as well. The frequency of a sound source will appear to change if the source or the observer are moving. Observed frequency will be greater than the source frequency when the source is approaching the observer and vice versa. An equation describes the observed frequency f' as a function of the velocity of the source if it is receding or approaching. The relative motion causes the shift in frequency, it doesn't matter if the source is moving or the observer. Here is the equation for a moving source, and stationary observer:

$$f' = \left(\frac{v}{v \pm v_s} \right) f_s$$

f' = the observed frequency

v = velocity of the wave (example: sound travels at 1088 ft/s)

v_s = velocity of the source relative to the observer, approaching source uses $-v_s$, receding source, uses $+v_s$.

If the observer is moving and the source is stationary, use this equation:

$$f' = \left(\frac{v \pm v_o}{v} \right) f_s$$

Unlike mechanical waves, for example snapping a rope and transferring a force from one end to the other, electromagnetic waves carry energy at the speed of light in a vacuum. They require no medium. The speed of light is 186,000 miles/ second. In an antennae, electrons vibrate in response to electromagnetic waves of the right frequency. Radio and television use electromagnetic waves to carry information.

An electromagnetic wave combines an electric field with a magnetic field.

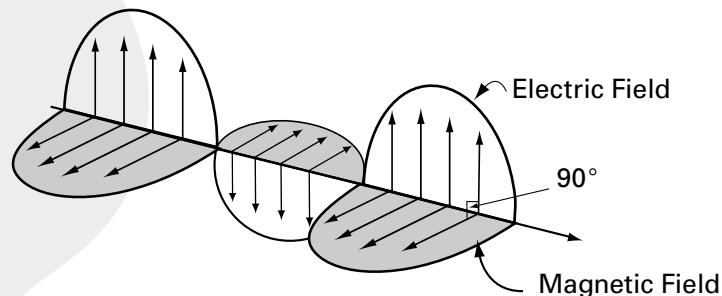



Unit 4 – Light

UNIT 4

Topic 1 – Electromagnetic Waves

The electric and magnetic fields are perpendicular to each other and to the direction the wave is traveling in.

Wavelength and frequency describe waves. Frequency is the number of cycles per second, and wavelength (λ) is the distance from crest to crest or trough to trough. The relationship between the wavelength, frequency and speed of light are given by:

$\lambda f = c$ where c is the speed of light. $c = 186,000$ miles/s, or 3×10^{10} m/s.

When the velocity of a wave is less than c , for example when a medium such as water slows down light, the product of wavelength and frequency will equal that velocity. In general $v = \lambda f$.

If you know any two you can find the third, and since c is a constant you can find wavelength when you know frequency and vice versa.

Example

Some light traveling in a vacuum has a frequency of 6×10^{14} Hz. What is the wavelength? What is the color of the light?

$$\lambda f = c$$

$$\lambda = \frac{c}{f} = \frac{3 \times 10^{10}}{6 \times 10^{14}} = 5 \times 10^{-5}$$

One Angstrom unit = 1×10^{-10} meters. A wavelength of 5×10^{-7} m is equal to 5000 Angstrom units, $\frac{5 \times 10^{-7}}{1 \times 10^{-10}}$, so it is in the uppermost end of visible violet light on the electromagnetic spectrum. The electromagnetic spectrum has many wavelengths and frequencies, with visible light forming only a small part of the spectrum as shown in the next diagram.

Frequency in Hz

10^2	10^4	10^6	10^8	10^{10}	10^{12}	10^{14}	10^{15}	10^{16}	10^{18}	10^{20}	10^{22}	10^{24}	
Power	Radio and TV	Infrared	Light		U_1V_1	X rays	Gamma rays						
10^{17}	10^{15}	10^{13}	10^{11}	10^{10}	10^9	10^7	10^6	10^3	10^1	1\AA	10^{-1}	10^{-3}	10^{-5}

λ in Angston units

$1\text{\AA} = 10^{-10}$ metres



Topic 1 – Electromagnetic Waves

The part of the spectrum for visible light ranges from 7000 Angstrom units for red, to 4000 Angstrom units for violet. The familiar acronym, "Roy G Biv", gives the colors in order of decreasing wavelength: red, orange, yellow, green, blue, indigo, violet. The shorter wavelength and higher frequency waves, for example gamma rays and x rays, can harm living tissue.

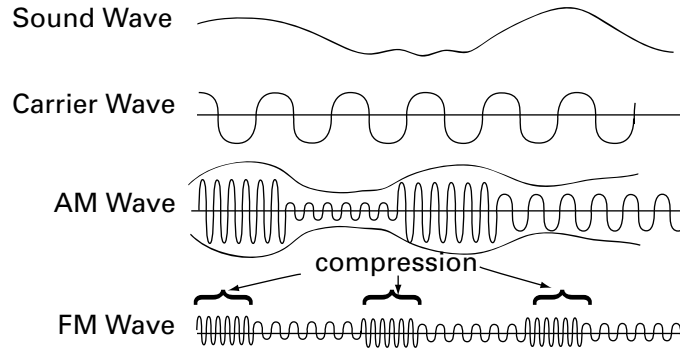

Radio and tv waves can be **modulated** so that information for sound and pictures can be carried by a wave at the speed of light. FM refers to frequency modulation, and AM to amplitude modulation. A sound wave can be represented either way by impressing it on an unmodulated carrier wave.





Topic 2 – Properties of Light

Light has been studied both as a particle and as a wave. The electromagnetic wave model helps to explain reflection and refraction. In particular, the phenomena of interference and diffraction are not properties of particles and cannot be explained by a particle theory – yet these are properties of light. Because light has such small wavelengths, it was easy to assume that light was a beam of particles traveling in straight lines. A summary of the evidence in favor of a wave theory of light follows next.

Diffraction

Diffraction is the bending that can be observed in a wave when it meets an obstacle. For example, a pan of water with a dividing panel that has a slit in it will show the horizontal water waves bending and becoming concentric rings on the other side of the panel.

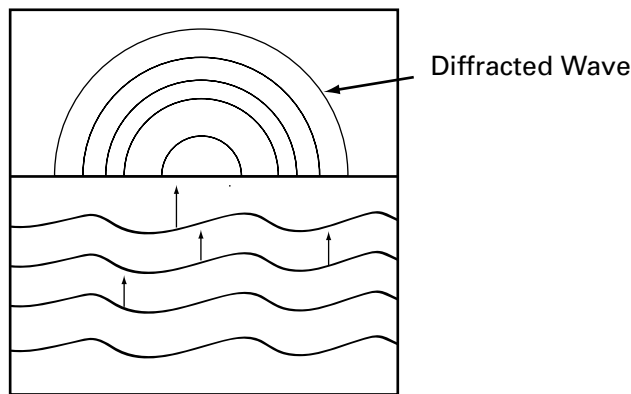

Light behaves the way the water waves do in a similar situation. A cone of light can be observed when a light is shone through a pinhole into a dark room.

Refraction

Light rays bend toward the perpendicular when they enter a medium where the speed of light is less. This happens when a beam of light goes from air to water. You may want to review refraction and the index of refraction, as well as geometric optics in Science Module 1 Unit six. If we think of light as a wave, then the wave front can be studied as a series of parallel lines. The first to reach the medium will bend away from the parallel towards the perpendicular.

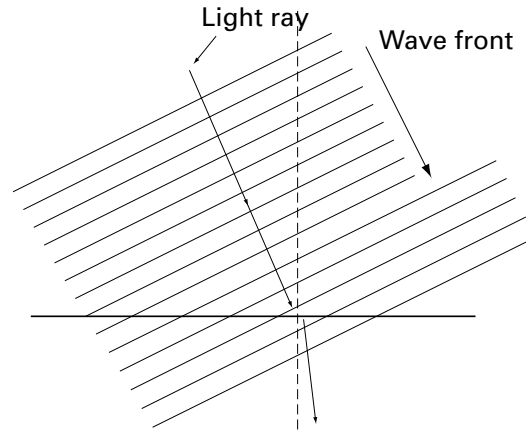

The part of the wave that reaches the boundary where the medium changes first, will be slowed down first, and the wave will bend. In the diagram, a light ray with an arrow is drawn to represent the bending effect on a cross section of the wave front. The ray shows the earlier optical view of light as a beam of particles rather than as a wave. The refraction was observed and describe by light rays, but not explained until the wave nature of light was understood.

Interference

A famous experiment by Thomas Young (1773-1829) gave support for the wave theory. Light was shone on a surface with two thin parallel slits. If light was made of beams (rays) of particles, then the light should travel through the slits and make two horizontal lines on a screen placed beyond the slits. In fact we see a series of horizontal lines of varying brightness that can be explained as the result of wave interference.

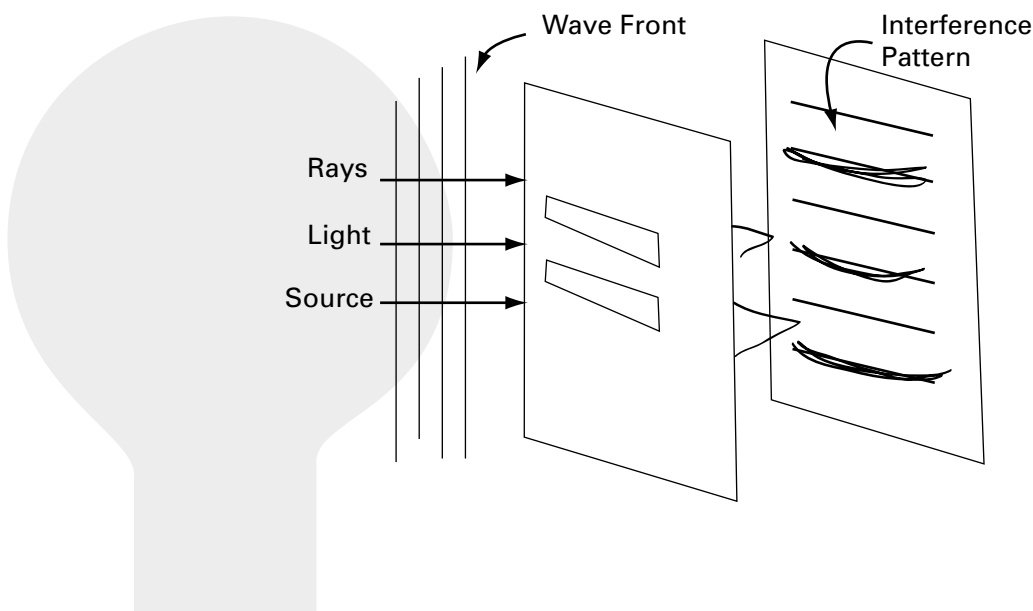



Topic 2 – Properties of Light

The wave front hits the slits just as water hit the slit in the pan in the earlier example of interference. Some of the lines (called fringes) on the screen are brighter where constructive interference occurs, and some are dark where destructive interference occurs. A bright area will be the result when the paths of the two rays are the same. The center of the screen has a bright area. If the wavelengths of the light coming through the slits differs by an integer multiple then there will be constructive interference and a bright fringe results. Here is a side view of the same experiment:

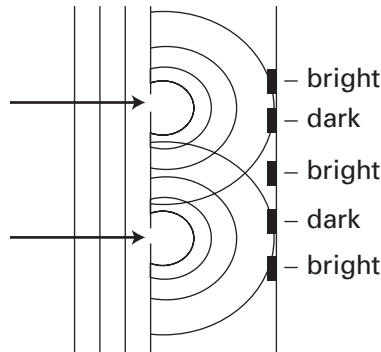

The wavelengths interfere destructively when the wavelengths differ by other than whole number factors. Young used the distance between fringes and their brightness to calculate wavelengths of light. He proved how small they are, from 4×10^{-7} m to 7.5×10^{-7} m.

Polarization

Light is a transverse wave because it shows the phenomenon of polarization, and longitudinal waves do not. A transverse wave will vibrate in a plane. For example if transverse waves are sent along a rope it can be snapped in the vertical y plane, the horizontal x plane or some plane that can be resolved into x and y components. If a slit is in the same plane as the wave it will pass through, otherwise not. A longitudinal wave cannot pass through a slit.

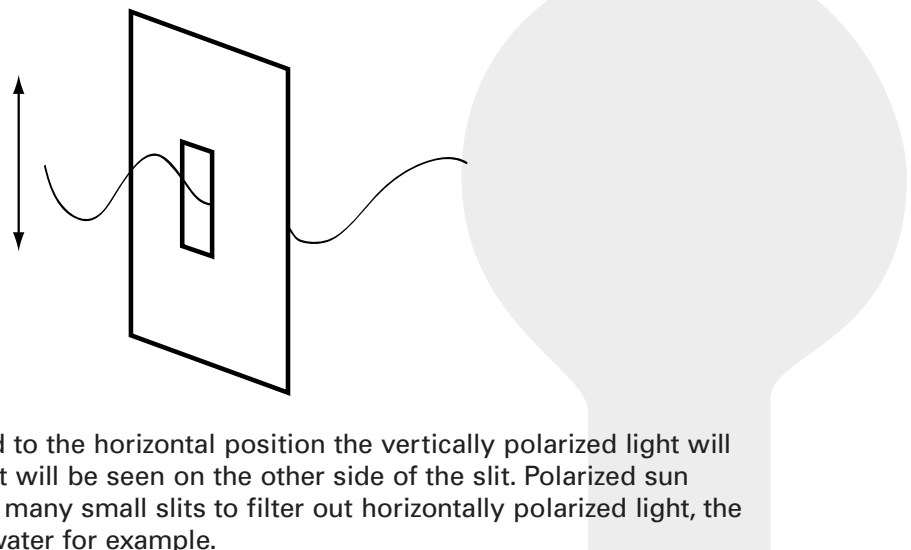

When the slit is rotated to the horizontal position the vertically polarized light will be blocked and no light will be seen on the other side of the slit. Polarized sun glasses are made with many small slits to filter out horizontally polarized light, the glare from roads and water for example.



Topic 2 – Properties of Light

Snell's Law And Total Internal Reflection

The angle of incidence and the angle of refraction in a change of medium are given by this equation:

$n_1 \sin q_1 = n_2 \sin q_2$ where n is the index of refraction for each medium.

If the change is from a more dense medium to a less dense medium, the light will be bent away from the perpendicular.

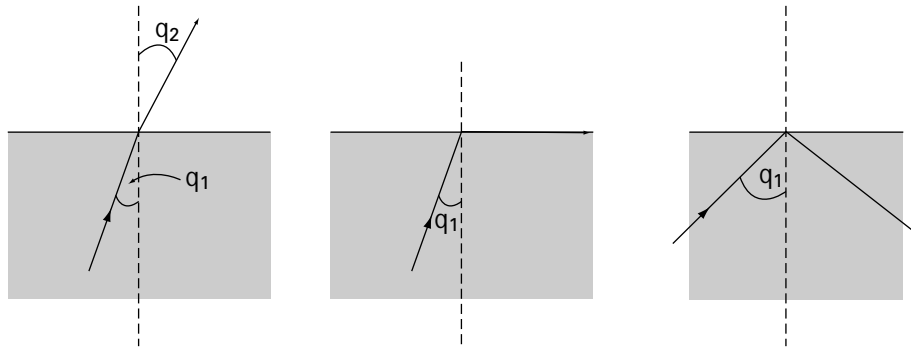

There will be a critical angle of incidence for any medium such that the angle of incidence will equal the angle of total internal reflection from the perpendicular as shown in the right hand figure of the diagram. The critical angle for internal reflection is given by:

$$\sin q_c = \frac{1}{n}$$

When the critical angle of internal reflection is reached the surface between the mediums acts as a mirror and total internal reflection occurs. The critical angle for total internal reflection for any medium can be calculated if n is known for each medium.

Example

What is the critical angle for the internal reflection in crown glass?
 n for crown glass = 1.5 and

$$\sin q_c = \frac{1}{n} = 1/1.5 = .67$$

$$q_c = \sin^{-1}(0.67) = 42^\circ$$



Topic 2 – Properties of Light

The Speed of Light

Light travels too quickly to be measured directly. One of the first accurate methods was carried out by Albert Michelson (1852-1931). He used a rotating eight sided mirror whose rate of rotation could be calibrated with a light source, a stationary mirror and an observer using a telescope. He set the mirror up on Mt. Baldy in California and the rotating mirror 35 miles away on Mt. Wilson. By knowing the speed of the rotating mirror when the reflection was seen steadily in the telescope, and by knowing the distance to the stationary mirror he calculated the speed of light to be 3.00×10^8 m/s.

Mirrors

An image focuses at half the radius of curvature when parallel rays hit a concave mirror.

$$f = \frac{r}{2}$$

Three rays will determine the focal point of a mirror. C is the point that is at the center of the sphere that would include the curved mirror as part of its surface.

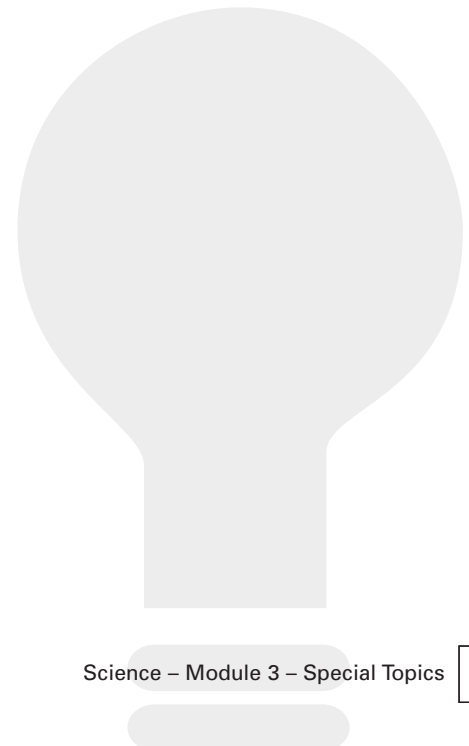
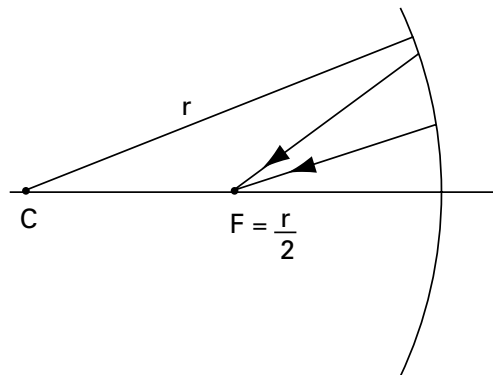



Unit 5

Practice Exam Questions for Science – Module 3 – Special Topics

This is the third of three sections in the science curriculum for trades entrance science exams. Science – Module 3 – Special Topics builds on Science – Module 1 – Science Foundations, and Science – Module Two – Science Development. Each section has a set of practice exam questions with an answer key. Each topic in the table of contents has sample questions to test your preparation for the trades entrance exam.

You should aim for 100%, and study the sections of the curriculum for any topics that you do not get right. After each answer the sections you should review are identified. Turn to the appropriate section of the curriculum whenever you need help.

Science Module 3 – Special Topics, is based on “need to know” competencies that are important for trades taking exam level 5. You may want to use the following sample exam questions both as a way of assessing what you need to learn before you work on the curriculum, and as a test of what you know after you have completed your preparation for the exam.

Answer Key

If you want to take a pre-test, select every fourth question, score yourself, and you will get an idea of what to study. After studying, try every third question and see how well you do and repeat the study cycle based on your results.

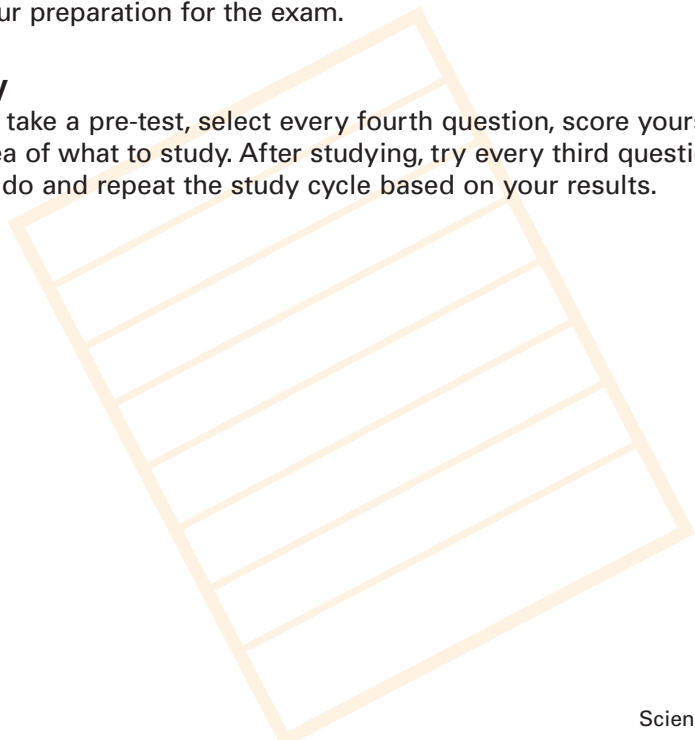

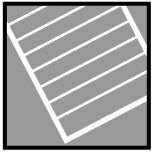

Unit One – Topic 1

Question 1

How does field theory help us to understand "action at a distance"?

- a) It explains the cause of gravity.
- b) It allows us to assign a value to a quantity based on its position in a field.
- c) It eliminates contact forces from the interaction between objects.
- d) It shows how electricity causes magnetism.

Answer: b

Question 2

What is an example of gravitational potential energy?

- a) A 10lb object on a table.
- b) A moving dog team.
- c) A tank full of gas.
- d) A waterfall.

Answer: a

Question 3

A positive charge (q_+) is put in an electric field and moves to a negatively charged metal plate 2cm away. What can be concluded about the charge on the metal plate?

- a) The plate is negatively charged.
- b) The plate is positively charged.
- c) The plate is neutral.
- d) The plate was lower than q_+ .

Answer: a

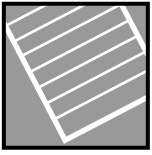

Unit One – Topic 1

Question 4

Magnetic fields can be produced by:

- a) gravitational force
- b) electric current
- c) electric charge
- d) voltage

Answer: b

Question 5

The force of gravity in a gravitational field is given by the equation:

- a) $E = PE + KE$
- b) $F = mgh$
- c) $F = k \frac{q_1 q_2}{r^2}$
- d) $F = G \frac{m_1 m_2}{d^2}$

Answer: d

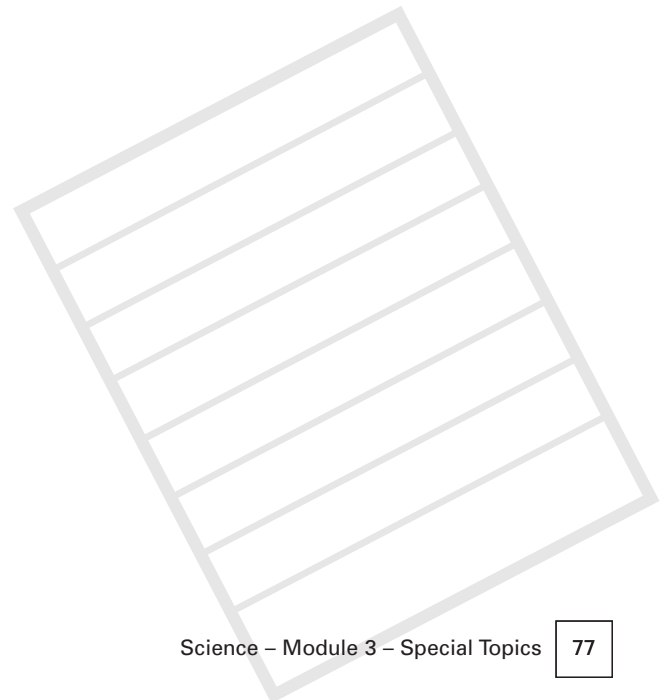

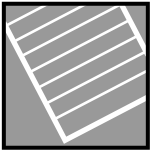

Unit 5 – Practice Exam Questions

UNIT 5

Unit One, Topic 2 – Velocity and Acceleration

Question 1

What is the displacement from A to B?

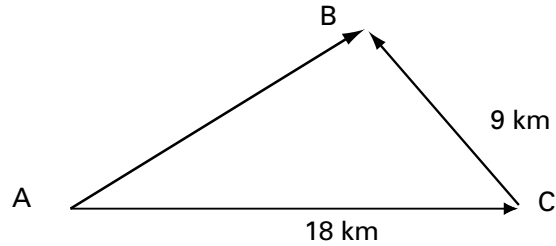

Scale: 1 cm = 3 km

- a) 10 km
- b) 15 km
- c) $18 \cos 30$
- d) 9 km

Answer: b

Question 2

How long will it take a 200 lb stone to fall 30 meters?

- a) 3.2 seconds
- b) 2.5 seconds
- c) 1.8 seconds
- d) 9.8 seconds

Answer: b

Question 3

A car travels 30 mph on the ice road for 20 minutes with constant velocity. What is the acceleration of the car?

- a) 3 feet/s²
- b) 30 feet/s²
- c) 0 feet/s²
- d) 30 mph²

Answer: c



Unit 5 – Practice Exam Questions

UNIT 5

Unit One, Topic 2 – Velocity and Acceleration

Question 4

What is the velocity of an object 3 seconds after it is dropped from a cliff?

- a) -30 feet/second
- b) -29.4 feet/second
- c) -45.9 feet/second
- d) -96 feet/second

Answer: b

Question 5

A car traveling 60 feet per second decelerates (slows down) at a uniform rate to 20 mph in 10 seconds on a snowy road. What is the car's deceleration?

- a) -4 feet/s²
- b) -32 feet/s²
- c) -6.6 feet/s²
- d) -12.2 feet/s²

Answer: a

Question 6

Which quantity is not a vector?

- a) Acceleration
- b) Velocity
- c) Displacement
- d) Average speed

Answer: d

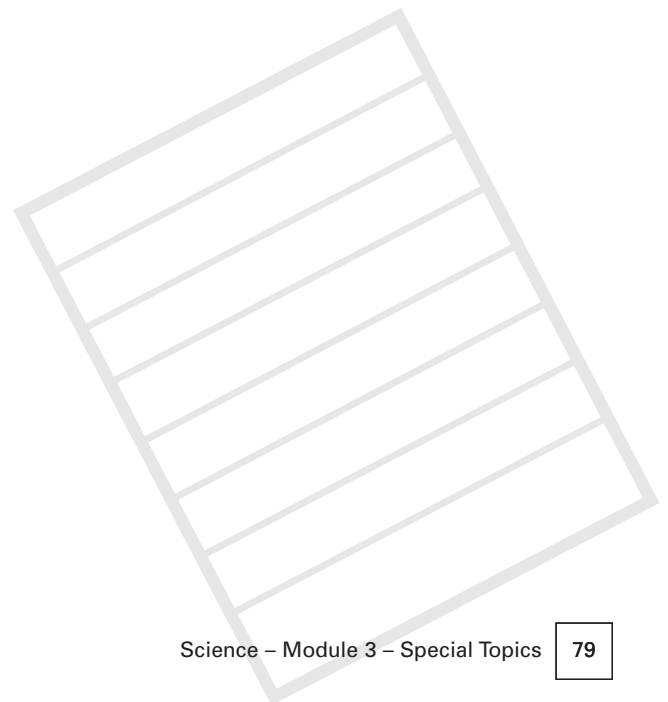

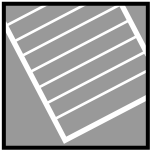

Unit 5 – Practice Exam Questions

UNIT 5

Unit One, Topic 2 – Velocity and Acceleration

Question 7

A trapper goes 3 miles west and then 4 miles due north. What is the displacement?

- a) 7 miles northwest
- b) 5 miles northwest
- c) 25 miles northeast
- d) 1 mile southeast

Answer: b

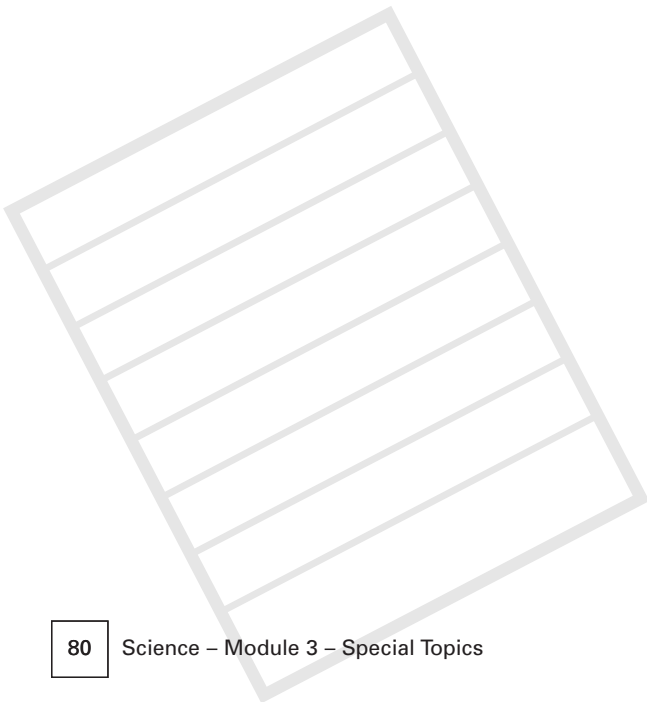



Unit 1, Topic 3 – Newton's Laws

Question 1

Will an object in motion keep moving if no force slows it down?

- a) No
- b) Yes
- c) Depends on friction
- d) Depends on acceleration

Answer: b

Question 2

Why do people jerk backward against their seats in a car when it accelerates suddenly?

- a) They have inertia.
- b) They aren't braced.
- c) They are being accelerated.
- d) They are reacting to a force.

Answer: a

Question 3

You are holding a pail of water that weighs 8 lbs. What exerts a downward force of 8 lbs on the pail?

- a) Your arm.
- b) The bottom of the pail.
- c) The water.
- d) Gravity.

Answer: d

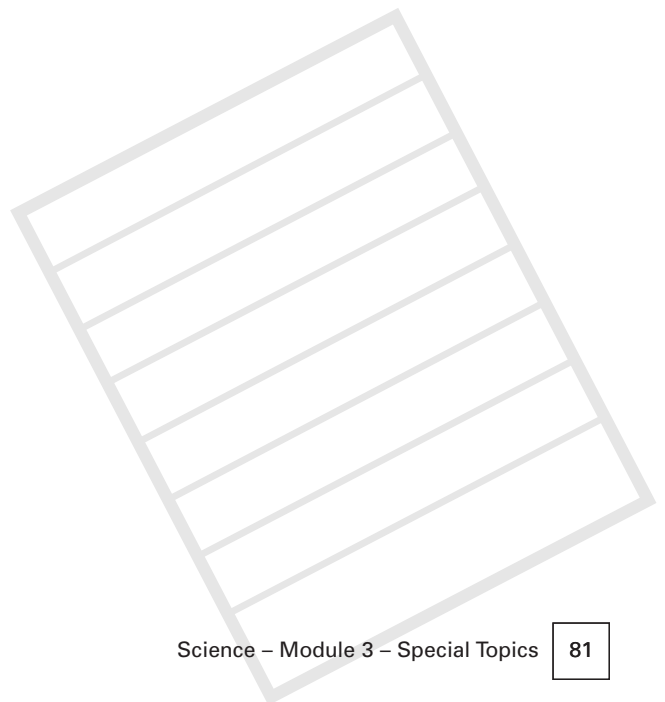

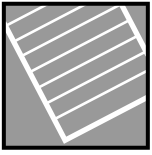

Unit 5 – Practice Exam Questions

UNIT 5

Unit 1, Topic 3 – Newton's Laws

Question 4

If you exert a force of 10 lbs upward on an 8lb book what will happen?

- a) The book will fall.
- b) The book will rise.
- c) The book will lose acceleration.
- d) The book will escape gravity.

Answer: b

Question 5

What amount of force is needed to make a 500 kg crate accelerate 1.6 m/s²?

- a) 800 Newtons
- b) 1000 kg
- c) 312.50 Newtons
- d) 1236 Newtons

Answer: a

Question 6

A bottle is on a table. Gravity exerts a downward force of 2 lbs. What force is equal and opposite to this force?

- a) The force of equilibrium.
- b) The force of the table on the bottle.
- c) The force of gravity minus the weight of the bottle.
- d) The force of the bottle on the table.

Answer: b

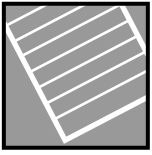

Unit 1, Topic 4 – Circular Motion

Question 1

How is it possible for a car traveling at a constant speed of 60 mph to be accelerating?

- a) It is impossible.
- b) It must be changing direction.
- c) It has to slow down or speed up.
- d) It is accelerating already.

Answer: b

Question 2

What is the centripetal acceleration of a car traveling around a circular track with a radius of .5 miles at 45 mph (66 feet/second)?

- a) 32.1 feet/s²
- b) 4.125 feet/s²
- c) 8.25 feet/s²
- d) 12.9 feet/s²

Answer: b

Question 3

What will happen to a satellite in uniform circular motion if it stops accelerating towards the center of the earth?

- a) It will fly off into space.
- b) It will slow down.
- c) It will orbit closer to the earth.
- d) It will fall to the earth.

Answer: a

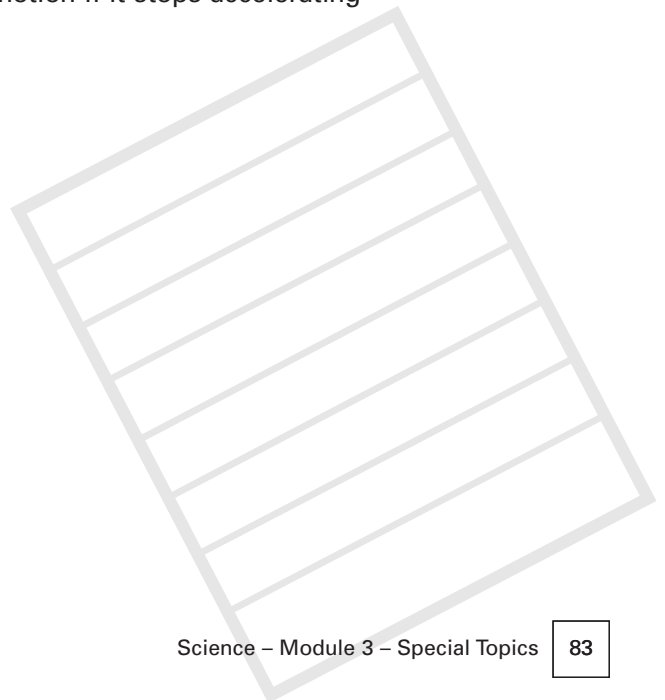

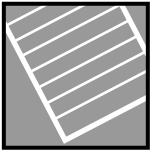

Unit 5 – Practice Exam Questions

UNIT 5

Unit 1, Topic 5 – Conservation of Momentum

Question 1

What is the definition of momentum?

- a) impulse x velocity
- b) mass x velocity
- c) velocity \div impulse
- d) acceleration \div mass

Answer: b

Question 2

What is the momentum of a 1 kg ball traveling at a speed of 10 m/s?

- a) 10 N
- b) .1 N
- c) 100 N
- d) .5 N

Answer: a

Question 3

What will be the velocity of a .1 kg tennis ball after it hits a racket at a speed of 3 m/s?

- a) 3 m/s
- b) .3 m/s
- c) 3.3 m/s
- d) .66 m/s

Answer: a



Unit 5 – Practice Exam Questions

UNIT 5

Unit 1, Topic 5 – Conservation of Momentum

Question 4

A car going 30 km/hr hits a second car with the same mass from the rear and locks bumpers so that they move forward together. If momentum is conserved, what is the velocity of the attached cars after the collision?

- a) 20 km/hr
- b) 10 km/hr
- c) 15 km/hr
- d) 8 km/hr

Answer: c

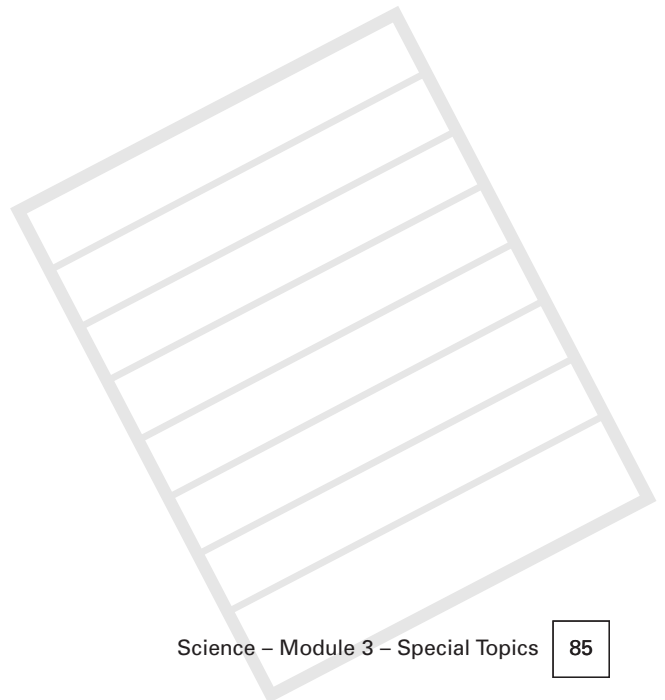

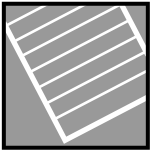

Unit 5 – Practice Exam Questions

UNIT 5

Unit 2, Topic 1 – Energy and Work

Question 1

Potential energy is changed into kinetic energy when a stone rolls down a hill because:

- a) the stone moved and did work.
- b) the gravitational energy was stored.
- c) the stone gained kinetic energy.
- d) the stone lost kinetic energy.

Answer: a

Question 2

Which is not a form of kinetic energy?

- a) Doing work.
- b) Heating a dinner.
- c) Lighting a room.
- d) Gravity.

Answer: d

Question 3

Kinetic energy can not be increased by:

- a) heat.
- b) putting an object 100 feet in the air.
- c) the radiant energy of the sun.
- d) speaking more loudly.

Answer: b

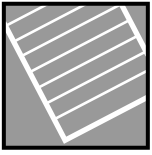

Unit 2, Topic 1 – Energy and Work

Question 4

Potential Electrical energy is released when a lightning bolt strikes the ground. What is moving from the sky to the earth?

- a) An electric charge.
- b) A convection current.
- c) A wave.
- d) Gravitational force.

Answer: a

Question 5

A stone is lifted and dropped on a stake to drive it into the ground. What does the kinetic energy of the stone depend on?

- a) The mass of the stone.
- b) The height of the stone above the stake.
- c) The force of dropping.
- d) The weight and height of the stone above the stake.

Answer: d

Question 6

A force of 100 pounds is needed to push a wheelbarrow of concrete 50 feet. How much work is done?

- a) 50 foot pounds
- b) 500 ft/lb
- c) 500 Newton/metres
- d) 2 foot pounds

Answer: b

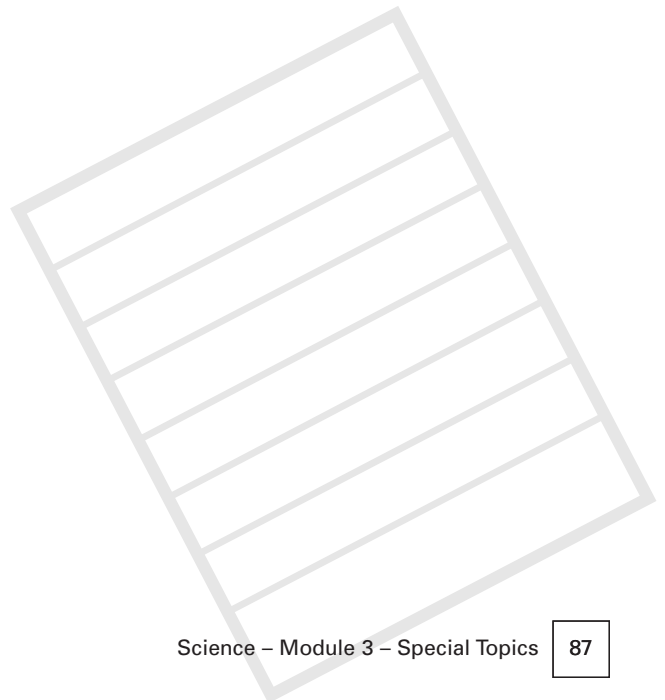



Unit 5 – Practice Exam Questions

UNIT 5

Unit 2, Topic 1 – Energy and Work

Question 7

How much work is being done by a man who holds a 2 pound flashlight 4 feet above the ground for 20 minutes in thirty below weather?

- a) 60 foot pounds
- b) 8 foot pounds
- c) no work is done
- d) 11 foot pounds

Answer: c

Question 8

How much work is done by 50 pounds of force that moves a fence post 6 inches into the ground?

- a) 300 inch pound
- b) 25 foot pounds
- c) 56 Newton/metres
- d) 300 joules

Answer: b

Question 9

How much force was applied to a rock that moved 10 metres after 500 joules of work was done on it?

- a) 5000 pounds
- b) 5000 Newtons
- c) 50 Newtons
- d) 500 Newtons

Answer: c

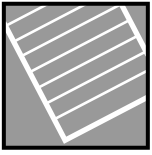

Unit 2, Topic 1 – Energy and Work

Question 10

How far did a car move if 300 foot pounds of work was done on it by an applied force of 150 pounds?

- a) 2 feet
- b) 450 feet
- c) 20 feet
- d) 4500 feet

Answer: a

Question 11

How much output work is done by a machine if a resistance of 300lb is moved 10 feet?

- a) 30 ft/lb
- b) 300 ft/lb
- c) 3000 ft/lb
- d) 310 ft/lb

Answer: c

Question 12

A person holds a pail of water for five minutes. How much work has been done?

- a) 5 minutes times the weight of the pail.
- b) The weight of the pail times the height from the floor.
- c) The force of gravity times five minutes.
- d) No work has been done.

Answer: d

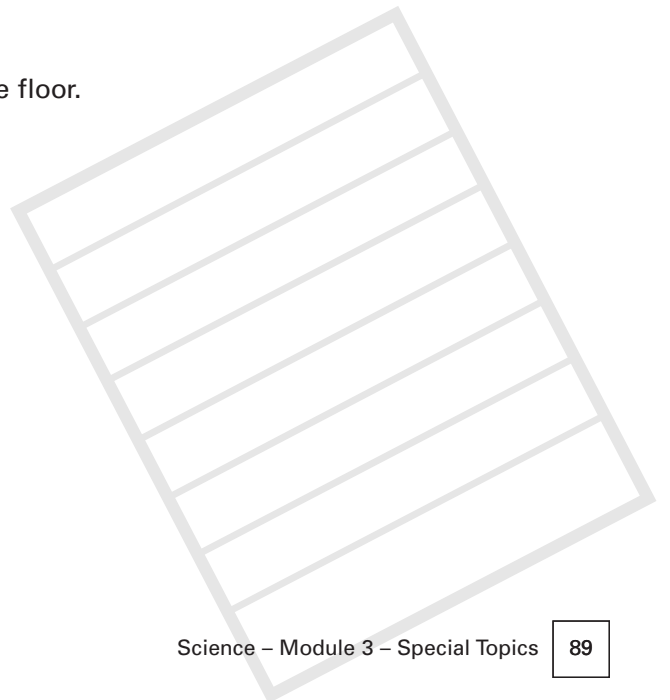

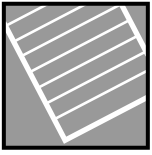

Unit 5 – Practice Exam Questions

UNIT 5

Unit 2, Topic 1 – Energy and Work

Question 13

The formula for work is:

- a) effort x weight
- b) force x distance
- c) input force x output force
- d) potential energy x kinetic energy

Answer: b

Question 14

When you rub your hands together and feel them getting warmer, what is happening?

- a) Heat energy is being changed into mechanical energy.
- b) Gravitational energy is being changed into heat energy.
- c) Mechanical energy is being changed into heat energy.
- d) Kinetic energy is being changed into potential energy.

Answer: c

Question 15

When you wind a clock you are:

- a) increasing the potential energy of the spring.
- b) releasing the kinetic energy of the spring.
- c) changing mechanical energy into kinetic energy.
- d) decreasing the force on the spring.

Answer: a

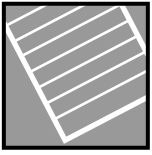

Unit 2, Topic 1 – Energy and Work

Question 16

A lightning bolt is an example of:

- a) gravity
- b) electrical energy
- c) mechanical energy
- d) radioactivity

Answer: b

Question 17

We calculate power in order to know:

- a) how much work is done.
- b) how fast work is done.
- c) how much energy was used to do work.
- d) how much effort was required to do work.

Answer: b

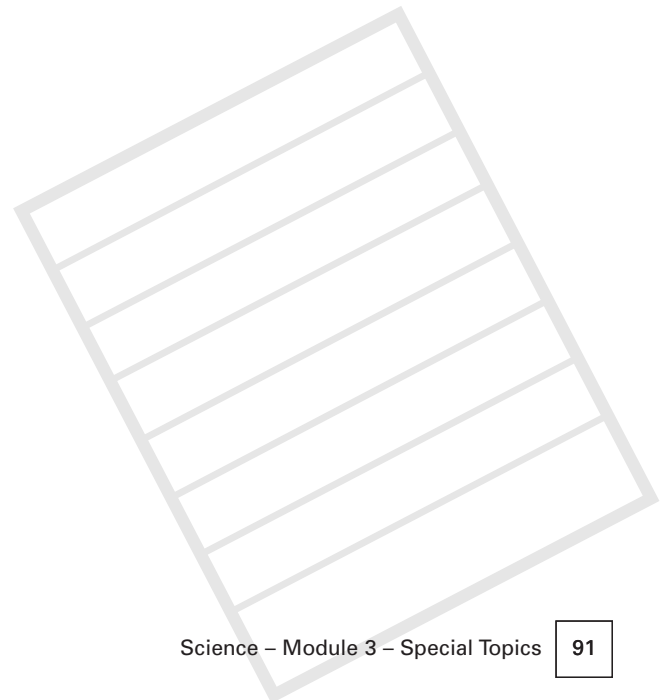

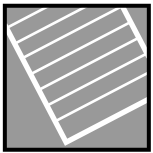

Unit Two, Topic 1 – Work and Energy

Question 1

When we say energy is conserved, what do we mean?

- a) The sum of initial energies is equal to the sum of final energies.
- b) The work done on a system is equal to the work done by the system.
- c) Potential Energy + Kinetic Energy = Total Energy.
- d) Energy gained = energy lost.

Answer: a

Question 2

A steam engine in a power plant is fired by oil. Chemical energy (oil) is converted to heat energy to drive a turbine in the plant. Steam enters the turbine chamber at 200° C, and exhausts at 400° C. What is the maximum possible efficiency this plant can achieve?

- a) 18%
- b) 50%
- c) 30%
- d) zero, the plant cannot do work

Answer: d

Question 3

The total change in energy internal to a system is equal to:

- a) The heat added to the system plus the work done by it.
- b) The heat removed from the system plus the work done by it.
- c) The heat added to the system minus the work done by it.
- d) The heat removed from the system plus the work done on it.

Answer: c

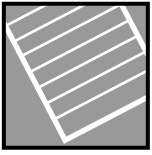

Unit Two, Topic 1 – Work and Energy

Question 4

A force is applied to lift a book from the floor onto a table. What has happened to the energy of the book?

- a) Nothing.
- b) It has doubled.
- c) Its potential energy has increased.
- d) Its kinetic energy has increased.

Answer: c

Question 5

Which kind of energy can do work?

- a) Electrical
- b) Chemical
- c) Mechanical
- d) a, b, and c

Answer: d

Question 6

Potential energy is due to:

- a) height or position
- b) weight
- c) force
- d) work

Answer: a

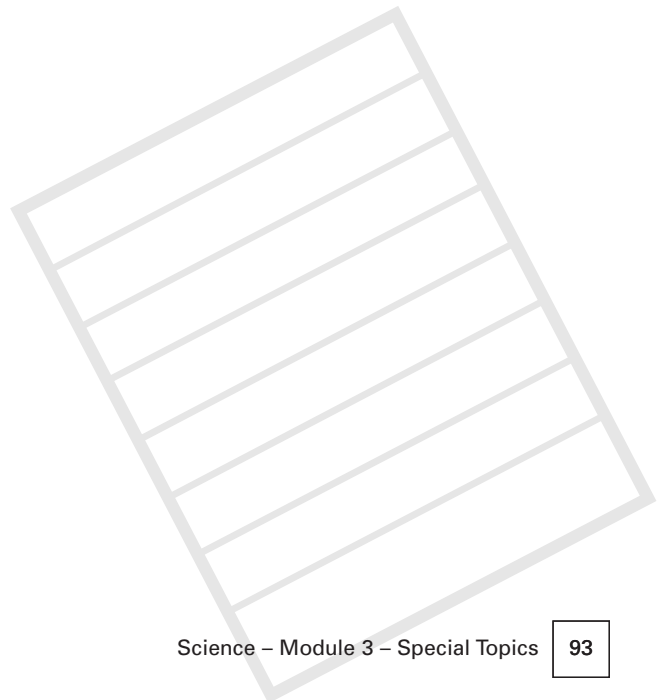

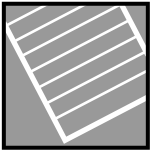

Unit 5 – Practice Exam Questions

UNIT 5

Unit Two, Topic 1 – Work and Energy

Question 7

Energy is neither created nor destroyed. What is this principle called?

- a) The equivalence of KE and PE.
- b) The principle of thermodynamics.
- c) The conservation of energy principle.
- d) The net work formula.

Answer: c

Question 8

Force and energy are related by the fact that:

- a) Net work done equals change in kinetic energy gained by an object.
- b) Force times distance equals work done on an object.
- c) Kinetic energy is all important.
- d) the potential energy of work done is conserved.

Answer: a

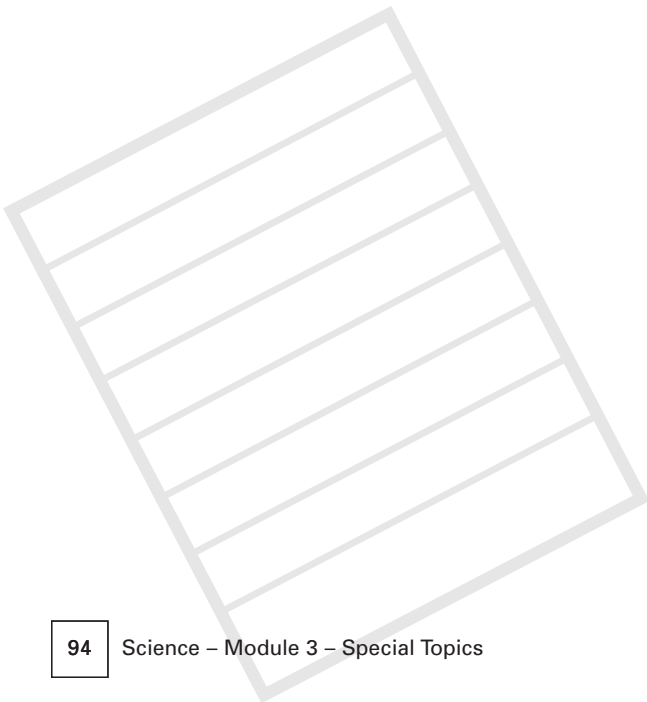

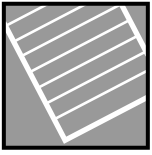

Unit 2, Topic 2 – Power

Question 1

A machine has a power of 250 watts. How much work can it do in 50 seconds?

- a) 6 Nm
- b) 6 joules
- c) 12,500 joules
- d) 200 joules

Answer: c

Question 2

One watt measures how much work is done in a unit of time. How much work is done if 20 watts is the rate of work for 60 seconds?

- a) 1200 joules
- b) 30 joules
- c) 300Nm
- d) 600 joules

Answer: a

Question 3

What is the power of a 60kg man who does 1800 joules of work climbing a 3 metre ladder in 60 seconds?

- a) 300 watts
- b) 180 watts
- c) 30 watts
- d) 1000 watts

Answer: c

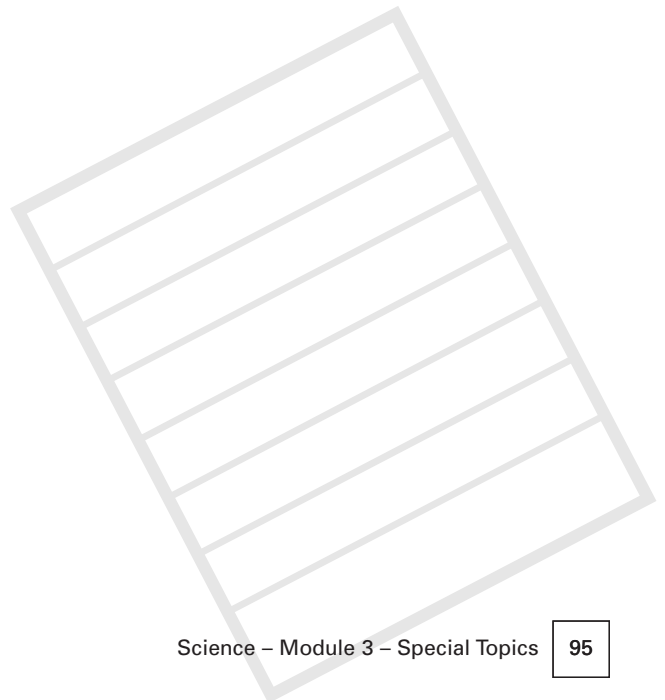

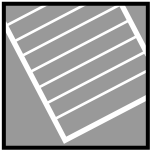

Unit 5 – Practice Exam Questions

UNIT 5

Unit 2, Topic 2 – Power

Question 4

It takes 30 minutes for a machine to do 300 foot pounds of work. What is the power of the machine?

- a) 600 foot pounds
- b) 10 foot pounds per minute
- c) 900 foot pounds per minute
- d) 9000 foot pounds per minute

Answer: b

Question 5

How many horsepower are equal to 5000 ft/lb of work completed in 10 minutes?

- a) 1.515 hp
- b) 500 hp
- c) 110.3 hp
- d) 5500 hp

Answer: a

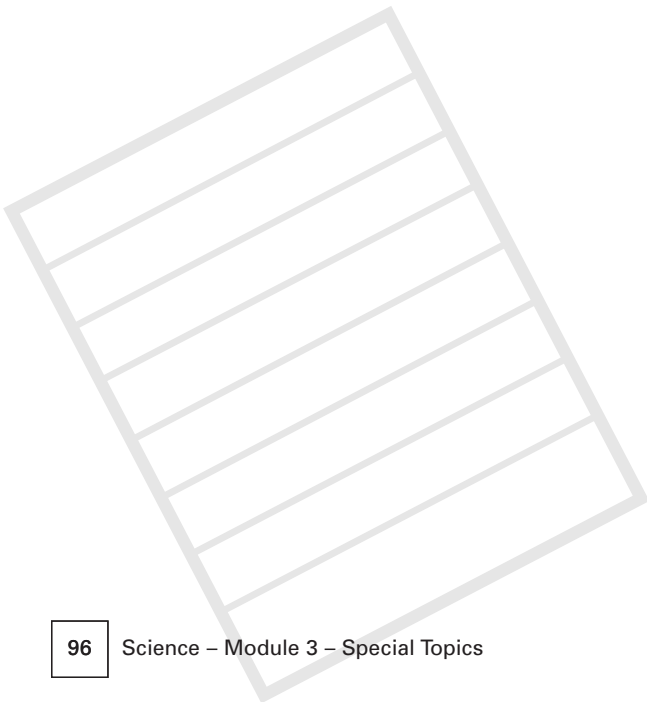

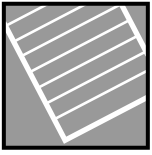

Unit 3, Topic 2 – Circuits

Question 1



A switch is used in a circuit to:

- a) increase current.
- b) decrease voltage.
- c) open and close the circuit.
- d) prevent shorts.

Answer: c

Question 2

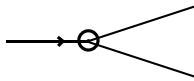
What is the symbol for a battery in a circuit diagram?

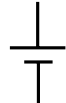
- a) 
- b) 
- c) 
- d) 

Answer: d

Question 3

The equivalent resistance in a series circuit is:

- a) the product of the individual resistances.
- b) the sum of the individual resistances.
- c) the difference between the individual resistances.
- d) the sum of the current through each resistance.

Answer: b



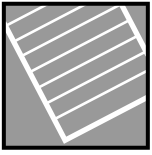

Unit 5 – Practice Exam Questions

UNIT 5

Unit 3, Topic 2 – Circuits

Question 4

A circuit will not conduct current if:

- a) the breaker is open.
- b) the resistances are in series.
- c) the battery is connected.
- d) the wire has junctions.

Answer: a

Question 5

A junction allows current to be:

- a) distributed to more than one path.
- b) returned to the battery.
- c) divided after each resistance.
- d) put into a parallel circuit.

Answer: a

Question 6

The current entering a junction is 27 amps. The current leaving the junction follows three branches. How many amps will travel down each branch?

- a) 81
- b) 27
- c) 9
- d) 3

Answer: c



Unit 3, Topic 2 – Circuits

Question 7

The electrical potential measured for a 12 volt battery is 0 volts. When this battery is connected to a circuit with two 4 amp bulbs in series, what will be the voltage across each bulb?

- a) 3 volts
- b) 8 volts
- c) 12 volts
- d) 0 volts

Answer: d

Question 8

In a series circuit with 3 resistors:

- a) the voltage drops are equal.
- b) the current is equal.
- c) the resistances are multiplied.
- d) the voltage is doubled.

Answer: b

Question 9

What is the voltage drop in a series circuit across a 12 ohm resistance supplied by a 12 volt battery?

- a) 6 volts
- b) 12 volts
- c) 3 volts
- d) 4 volts

Answer: b

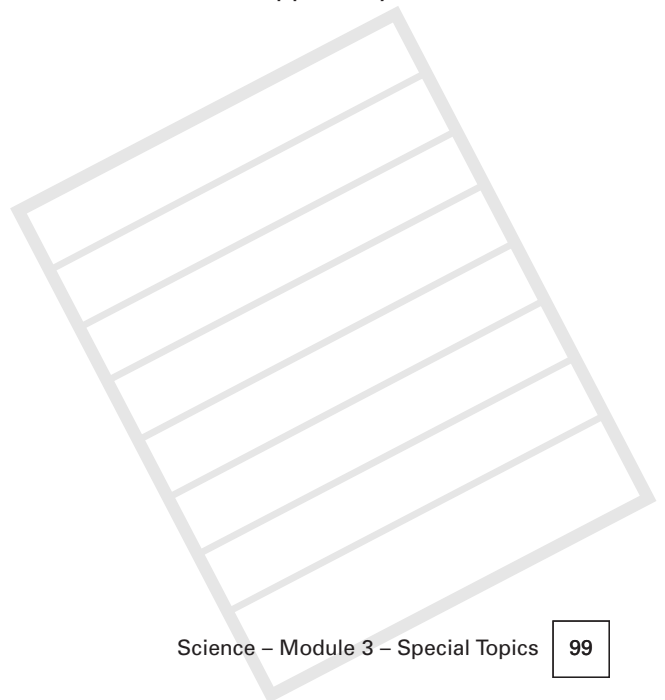



Unit 3, Topic 2 – Circuits

Question 10

What is the equivalent resistance in a series circuit that draws 6 amps for 12 ohm, 6 ohm, and 3 ohm bulbs?

- a) 9 ohms
- b) 36 ohms
- c) 18 ohms
- d) 21 ohms

Answer: d

Question 11

A 12 volt battery supplies a circuit with 3 resistances in series. The voltage drop over the first resistance is 3 volts, and the voltage drop over the third is 2 volts. What is the voltage drop over the second resistance?

- a) Can't tell from this information
- b) 5 volts
- c) 7 volts
- d) 6 volts

Answer: c

Question 12

A bulb burns out in a series circuit shared with 10 other bulbs. What will happen to the other bulbs?

- a) Only the downstream bulbs will go out.
- b) Only the upstream bulbs will go out.
- c) All of the bulbs will go out.
- d) The remaining 9 bulbs will remain lit.

Answer: c

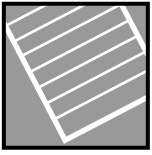

Unit 3, Topic 2 – Circuits

Question 13

A parallel circuit has two resistors. One is 12 ohms, and one is 4 ohms. What will be the total resistance?

- a) 16 ohms
- b) 4 ohms
- c) 6 ohms
- d) 3 ohms

Answer: d

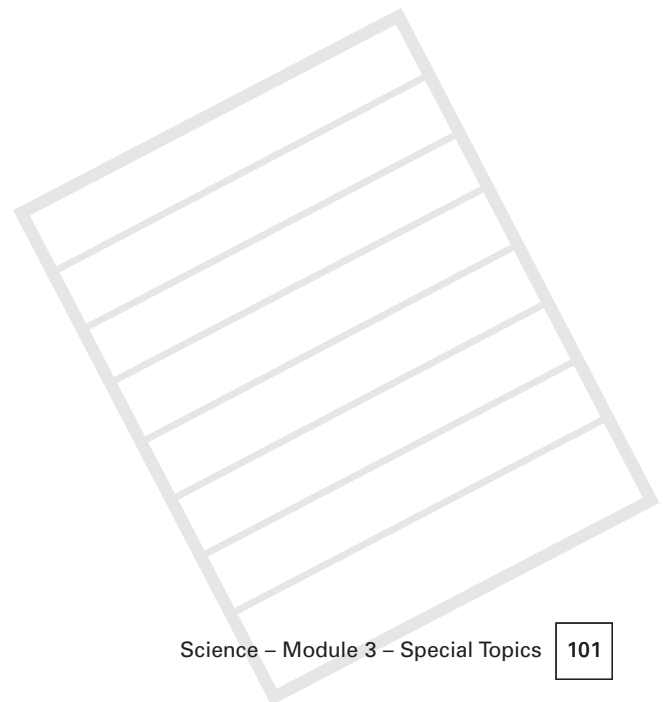

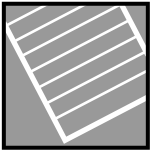

Unit 5 – Practice Exam Questions

UNIT 5

Unit 3, Topic 3 – Electrical Power

Question 1

How many kilowatt hours will a toaster rated at 1200 watts use in a two hour period of operation?

- a) .600 kWh
- b) 1.2 kWh
- c) 2.4 kWh
- d) 1.4 kWh

Answer: c

Question 2

What will it cost to operate an electric blanket for 6 hours that is rated at 180 watts if 1 kWh costs \$.10?

- a) \$.180
- b) \$1.70
- c) \$.108
- d) \$.300

Answer: c

Question 3

A Yellowknife apartment dweller is billed \$40.00 for one month's use of an electric heater that is rated at 1400 watts. He pays \$.20 for every kWh. How many hours did he run the heater during the month?

- a) 80 hours
- b) 142.85 hours
- c) 80.45 hours
- d) 800 hours

Answer: b

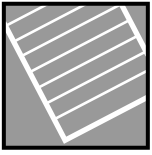

Unit 5 – Practice Exam Questions

UNIT 5

Unit 3, Topic 3 – Electrical Power

Question 4

John wants to limit his monthly cost for operating his 4000 watt water heater in Inuvik to \$25.00. If power costs \$.10 per kWh, how many hours can he operate his water heater before going over his target of \$25.00?

- a) 80 hours
- b) 62.5 hours
- c) 75.4 hours
- d) 425 hours

Answer: b

Question 5

How much will it cost if a 400 watt refrigerator runs continuously for 12 days and each kWh costs \$0.15?

- a) \$72.25
- b) \$27.28
- c) \$18.25
- d) \$17.28

Answer: d

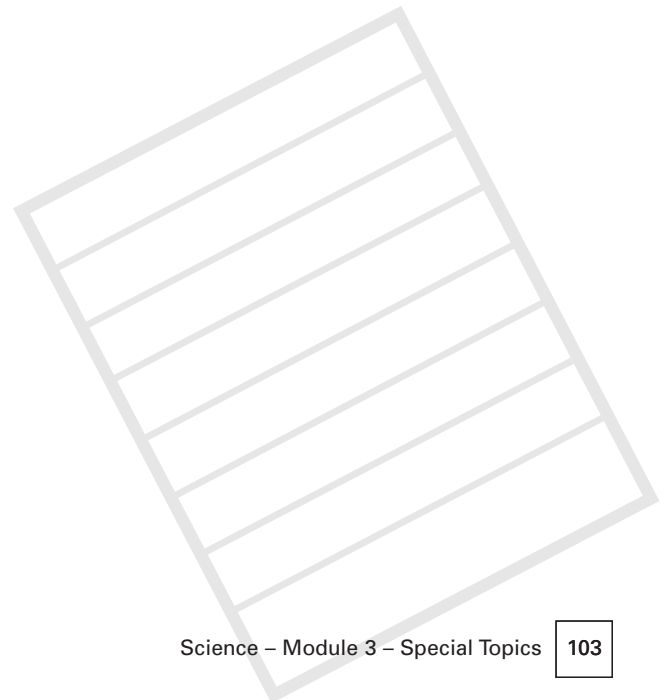

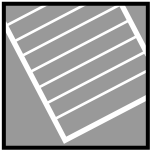

Unit 5 – Practice Exam Questions

UNIT 5

Unit 3, Topic 3 – Transformers

Question 1

A transformer has 100 turns in the primary coil, and 50 turns in the secondary coil. What will be the output voltage if 120 volts is supplied to the primary coil?

- a) 30 volts
- b) 40 volts
- c) 60 volts
- d) .3 volts

Answer: c

Question 2

Why is dc current unable to make a transformer work?

- a) It is too weak.
- b) It alternates irregularly.
- c) It produces a constant magnetic field in the secondary coil.
- d) It doesn't have flux.

Answer: c

Question 3

The current put into the primary coil of a transformer is 5 amps and the input voltage is 40 volts. If the output current from the secondary coil is 20 amps, what is the output voltage?

- a) 200 volts
- b) 10 volts
- c) 100 volts
- d) 80 volts

Answer: b



Unit Four, Topic 1 – Electromagnetic Waves

Question 1

A transverse wave interferes with another wave having the same amplitude and period. What is the result?

- a) Constructive interference.
- b) Destructive interference.
- c) Refraction.
- d) Frequency modulation.

Answer: a

Question 2

A radio wave carries an impressed sound wave by:

- a) accelerating the wave.
- b) modulating the amplitude or frequency.
- c) decreasing the signal periodically.
- d) developing momentum.

Answer: b

Question 3

Which formula relates the wavelength, frequency and velocity of a wave correctly?

- a) wavelength \times frequency = velocity
- b) wavelength \div frequency = velocity
- c) frequency \div velocity = wavelength
- d) velocity \times wavelength = frequency

Answer: a

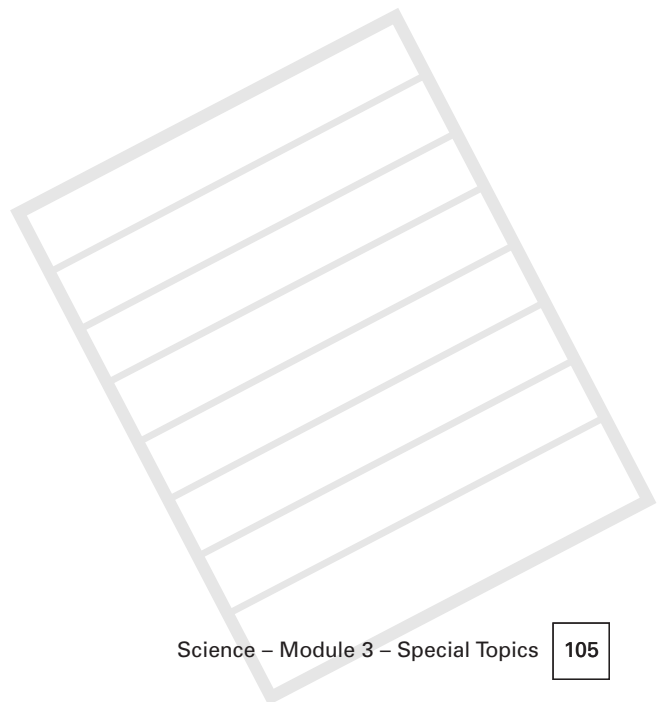

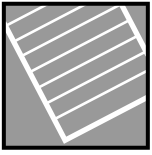

Unit 5 – Practice Exam Questions

UNIT 5

Unit Four, Topic 1 – Electromagnetic Waves

Question 4

Which electromagnetic frequency (in Hz) could be harmful to living tissue?

- a) 10^6
- b) 10^{14}
- c) 10^{22}
- d) 10^{10}

Answer: c

Question 5

An oncoming train traveling at 60mph blows its horn. What will happen to the frequency of the sound?

- a) It will decrease.
- b) It will increase.
- c) It will remain the same.
- d) It will double its frequency.

Answer: b

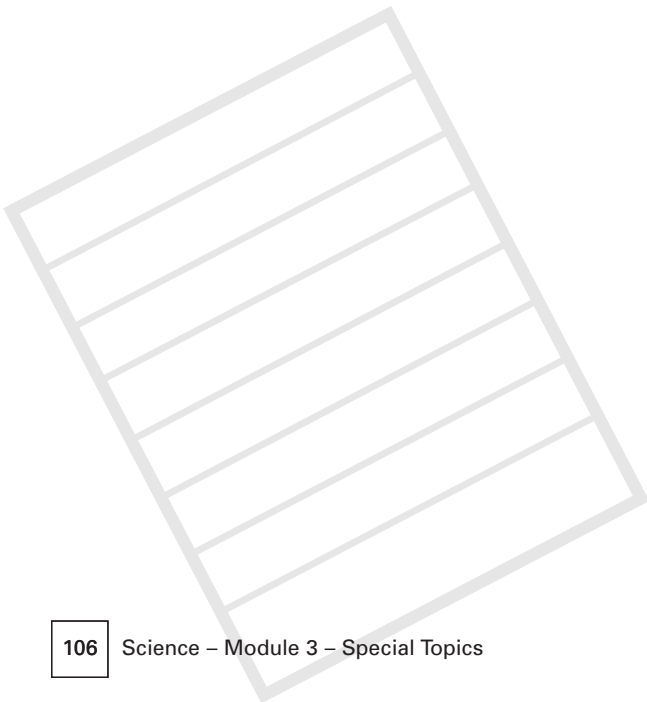



Unit 4, Topic 2 – Properties of Light

Question 1

What provides support for the wave theory of light?

- a) Polarization of light.
- b) Young's double slit experiment.
- c) Diffraction.
- d) All of the above.

Answer: d

Question 2

What is true about reflection?

- a) The focal point is always one half of the radius.
- b) The angle of incidence equals the angle of reflection.
- c) Light will reflect better as a wave.
- d) The reflection will be a virtual image.

Answer: b

Question 3

What is the critical angle of total internal reflection?

- a) The angle of incidence after it bends.
- b) The angle between the refractive index and the perpendicular.
- c) The angle that makes light reflect below the horizontal boundary of a medium.
- d) The angle that polarizes light.

Answer: c

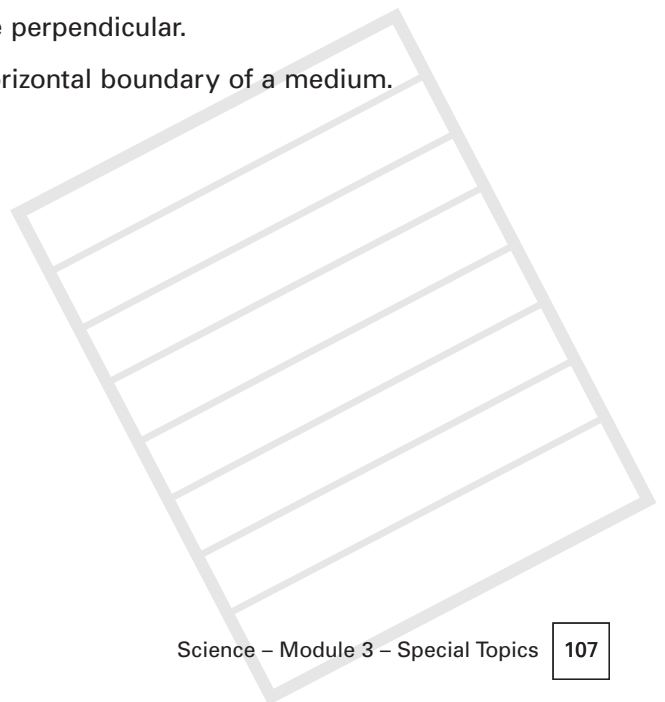

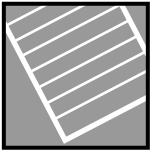

Unit 5 – Practice Exam Questions

UNIT 5

Unit 4, Topic 2 – Properties of Light

Question 4

What does polarization prove about light?

- a) That it is a compression wave.
- b) That it is a longitudinal wave.
- c) That it is a transverse wave.
- d) That it has interference.

Answer: c

Question 5

An image focuses 6 inches from a concave mirror. What is the radius of curvature of the mirror?

- a) 6 inches
- b) 12 inches
- c) 18 inches
- d) 4 inches

Answer: b

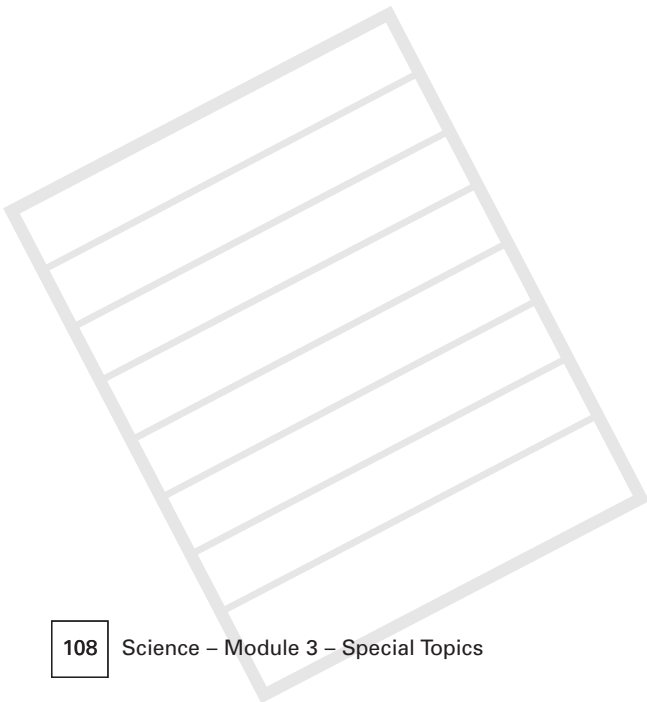



Resources

Bueche, Frederick, Principles of Physics, 5th Edition, McGraw Hill, 1988.
(ISBN 0-07-008892-6).

Giancoli, Douglas, The Ideas of Physics, Third edition, Harcourt Brace 1986.
(ISBN 0-15-540562-4).

Ibid., General Physics, Prentice Hall, 1984. (ISBN 0-13-350884-6).

Haber-Scham et al, PSSC Physics, Seventh edition, Kendall/Hunt publishing, 1986.
(ISBN 0-8403-6025-8).

Hazen, Robert, Science Matters: Achieving Scientific Literacy, Doubleday, 1991.
(ISBN 0-385-24796-6).

Kirkup, L et al, Essential Physics, Pitman, London,1983. (ISBN 0-273-01896-5).

Long, Frank, Introductory Electricity, 3rd Edition, Irwin, Toronto, 1989.
(ISBN 0-7725-1718-5).

Seese, William, Basic Chemistry, fifth edition, Prentice Hall, 1988.
(ISBN 0-13-057795-2).

Serway and Faughn, College Physics, Saunders College Publishing, 1985.
(ISBN 0-03-062378-2).

Singer, Bertrand, Basic Mathematics for Electricity and Electronics, 3rd edition,
McGraw Hill, 1972. (LOC# 77-170866-07-057467-7).

Williams, John, Modern Physics, Holt Rinehart and Winston, 1984.
(ISBN 0-03-061936-X).

Wilson, Jerry, Technical College Physics, 2nd edition, CBS College Publishing, 1987.
(ISBN 0-03-008494-6).

Appendix: Alberta List of Competencies

Module Three of this science curriculum, Special Topics, reviews the following requirements from the Alberta trades entrance curriculum. The numbers in brackets indicate the exam levels that include these competencies.

SCIENCE MODULE 3 – SPECIAL TOPICS

A. Field Theory As An Important Idea In Modern Science

Outcome: Describe field theory as one of the most important ideas in modern science. (5)

1. Define a field as the value of a quantity by virtue of position.
2. Describe the basic characteristics of all vector fields, source, direction and strength of field, as determined by a test object.
3. Compare gravitational, electric and magnetic fields in terms of basic characteristics.

B. Applications of Field Theory

Outcome: Explain the operation of many important electric devices using field theory. (5)

1. Describe the relationships among current, voltage and resistance, using Ohm's law.
2. Describe the relationships among power, current, voltage and resistance.
3. Compare the resistances in series and parallel circuits.
4. Distinguish between alternating current and direct current in terms of electron movement and electric field.
5. Describe the advantages of alternating current over direct current for transmitting and using electrical energy.
6. Explain the operation of a transformer in terms of the relationship among current, voltage, and the number of turns in the primary and secondary coils.
7. Use a mechanical (collision) model to illustrate electric current and resistance in conductors.
8. Calculate any variable in the equation $V = IR$, given the other two variables.
9. Calculate any variable in the equation $P = VI$, given the other two variables.
10. Calculate any variable in the equation $P = I^2R$, given the other two variables.
11. Calculate simple series and parallel circuits involving up to three resistors,

Appendix

and measure the voltage, current and resistance.

12. Calculate resistance for series and parallel circuits involving up to three resistors.
13. Investigate the effect of a conductor moving through a magnetic field.
14. Build or demonstrate a simple electric motor.
15. Compare electric motors and generators.
16. Investigate the relationships among the current, voltage and number of turns in the primary and secondary coils of a transformer.

C. Motion Of Objects

Outcome: Describe motion of objects in terms of displacement, time, velocity and acceleration. (5)

1. Compare scalar and vector quantities.
2. Compare distance and displacement, and speed and velocity.
3. Define velocity as a change in position during a time interval.
4. Define acceleration as a change in velocity during a time interval.
5. Use scale diagrams to solve displacement problems in two dimensions.

D. Newton's Laws Of Motion

Outcome: Explain how Newton's laws of motion relate force to the motion of objects. (5)

1. Compare mass and weight, qualitatively.
2. Explain how a force effects a change in motion.
3. Apply Newton's first law of motion to explain an object's state of rest or uniform motion.
4. Apply Newton's second law of motion, and use it to relate force, mass and motion.
5. Apply Newton's third law of motion to explain situations where objects interact.

E. Uniform Circular Motion

Outcome: Describe how an object moving in a circular path, with a constant speed, undergoes acceleration toward the centre of the circle. (5)

1. Describe uniform circular motion as a special case of two-dimensional motion.
2. Describe a centripetal force as having one of several sources.
3. Apply the centripetal force and acceleration equations to uniform circular motion.
4. Illustrate, qualitatively, Newton's universal law of gravitation as it applies to planetary and satellite motion.

Appendix

F. Conservation Of Momentum

Outcome: Explain how momentum is conserved in physical interactions. (5)

1. Define momentum as a quantity of motion equal to the product of the mass and the velocity of an object.
2. Relate the role of change in momentum to acceleration.
3. Apply the law of conservation of momentum to linear collisions and explosions.
4. Explain one-dimensional collisions and explosions, using scale diagrams and numerical means.

G. Energy Transfer

Outcome: Describe how energy can be transformed from one form to another. (5)

1. Recognize that potential energy is only useful when it is transformed to some form of kinetic energy.
2. Illustrate, by use of examples, that energy transfers produce measurable changes in motion, shape or temperature of matter.
3. Define gravitational potential energy as the work done on a mass against gravity, and quantify gravitational potential energy.
4. Quantify kinetic energy.
5. Recognize chemical energy as a form of potential energy.
6. Quantify electrical energy.
7. Analyze units to describe the kilowatt-hour as a unit of energy, and the watt as a unit of rate of energy transfer or a unit of rate of doing work.

H. Conservation Of Energy

Outcome: Illustrate The Law Of The Conservation Of Energy. (5)

1. State the law of conservation of energy, as "the sum of initial energies is equal to the sum of final energies".
2. Recognize the first law of thermodynamics as a statement of the law of conservation of energy.
3. Describe by use of examples, that thermal energy will, of its own accord, flow from a hotter body to a cooler body, and recognize this as a formal statement of the second law of thermodynamics.
4. Compare the mechanism of diffusion to thermal energy transfer according to the second law of thermodynamics.

Appendix

I. Energy Efficiency

Outcome: Explain how useful energy diminishes during any energy transformation. (5)

1. Interpret empirical data from a study of energy conversions.
2. Explain that energy conversion processes have different efficiencies, based on total energy input compared to the net useful energy output.
3. Define efficiency as a measure of the useful work compared to the total energy put into an energy conversion process.
4. Define inefficiency as the fraction of energy lost as wasted heat in the conversion process.
5. Describe techniques for reducing waste of energy, in a common household device.

J. Geometric Optics

Outcome: Explain the nature and behaviour of light using the geometric optics model. (5)

1. Cite evidence for the linear propagation of light.
2. Explain a method of measuring the speed of light.
3. Calculate given experimental data of various methods employed to measure the speed of light.
4. Define a ray as a straight line representing the rectilinear propagation of light.
5. Explain, using ray diagrams, the phenomena of dispersion, reflection and refraction at plane and uniformly curved surfaces.
6. State and use Snell's law.
7. Derive the curved mirror equation from empirical data.
8. Solve reflection and refraction problems, using algebraic, trigonometric and graphical methods.
9. Analyze simple optical systems, consisting of no more than two lenses or one mirror and one lens, using algebraic and/or graphical methods.

K. Light Waves

Outcome: Describe how the wave model of light improves our understanding of the behaviour of light. (5)

1. Compare the explanations of reflection and refraction by the particle theory and by the wave theory of light.
2. Explain, using the wave theory of light, the phenomena of reflection and refraction.
3. Explain why geometric optics fail to adequately account for the phenomena of diffraction, interference and polarization.
4. Explain, qualitatively, diffraction and interference, using the wave model of light.
5. Explain how the results of Young's double-slit experiment support the wave theory of light.
6. Solve double-slit problems and diffraction grating problems.
7. Explain, qualitatively, polarization in terms of the wave model of light.
8. Demonstrate how Snell's law offers support for the wave model of light.

Appendix

L. Electromagnetic Spectrum

Outcome: Describe the electromagnetic spectrum as a continuous range of electromagnetic waves with specific characteristics and similar properties. (5)

1. Predict the effects of changing one, or a combination, of variables in the relationship defining wavelength and frequency.
2. Describe the range of the electromagnetic spectrum from long, low frequency radio waves, through microwaves, infrared, visible, ultraviolet and X-rays, to very short, high frequency gamma rays.
3. Explain the difference between AM and FM radio waves in terms of amplitude and frequency modulation.
4. Compare to each other, the various constituents of the electromagnetic spectrum on the basis of source, frequency, wavelength, energy and effect on living tissue.
5. Describe, qualitatively, the phenomena of reflection, refraction and polarization of visible light.
6. Compare, the characteristics of radiation from any region of the electromagnetic spectrum with those of visible light.
7. Calculate any variable given two of the three variables of frequency, wavelength and speed of electromagnetic propagation.
8. Perform and evaluate experiments that investigate reflection and refraction of visible light.
9. Perform an experiment to demonstrate total internal reflection.
10. Perform an experiment to demonstrate the polarization of visible light.
11. Draw diagrams to illustrate amplitude and frequency modulated radio waves.

